

Vault Style Gas Insulated Switching Solutions



After a century of engineering exceptionally long lasting medium-voltage distribution products, G&W Electric knows power. And more importantly, we know the power of listening. By taking time to understand your application and asking the right questions, we develop a solution that precisely matches your needs. The answer may be our time-tested switches that keep power running seamlessly in mission-critical industries, or an advanced automation system for next-generation smart grids. Whatever your challenge, you'll experience decades of high-performance engineering to meet your needs.

Gas Insulated Solution

We are dedicated to delivering proven solutions that meet and exceed your needs. That's why our engineers ask you questions and listen to find the right solution.

Our gas insulated vault switches provide load and fault interrupting switching for systems rated through 38kV, 1200A continuous bus, 900A continuous and switching ways, to 25kA symmetrical interrupting. They offer:

- Smart Grid/Lazer® Solutions
- Submersible designs
- Dead-front designs
- Compact construction
- Maintenance-free operation
- Two and three position switching
- Mounting flexibility
- Ease of Automation



Maximum Operator Safety

Dead front switch construction eliminates any exposed live parts. Spring-assisted mechanisms assure quick make, quick-break operation. Viewing windows permit visual verification of open or closed contacts. Tamper resistant enclosures utilize pentahead bolts and padlocking provisions. Motor actuators are available permitting remote operation. The result is maximum operator safety.

Minimal Maintenance

G&W Electric's gas insulated switches are corrosion-resistant, totally sealed and factory filled. No more field adjustments of critical contact areas or concerns with environmental contamination or intrusions. A periodic check of the pressure gauge is all that is required.

Application Versatility

Multi-way Configurations – Switches are available for either two-position or three-position (incorporating an integral ground, tie or test position) switching. Single or multiple sources can feed multiple loads. Bus tie configurations are available permitting multiple sources to feed different loads within the same switch

Mounting Flexibility – Horizontal and vertical configurations are available with operating apparatus accessible from the front, top or side compartments

Bushing Variety – Many bushing styles are available including an exclusive disconnectable style permitting field change-out. Cable entry can be bottom, front, back or side. Transformer throat designs are available.

Visible Break – Load break switches can incorporate a visible break of all three phases. Overcurrent Protection – Fusing or electronically controlled, resettable vacuum interrupters are available.

Smart Grid / Lazer Solutions – Complete distribution automation and Smart Grid solutions are available including automatic transfer. G&W's Lazer distribution automation systems provide pre-engineered, time-proven solutions for automatic power restoration.



Features include:

Puffer Vacuum Interrupters offer:

- Load and fault interrupting combination switches are designed for automatic single or three phase fault interruption with manual loadbreak capabilities
- Ratings include systems through 35kV, 630A continuous. Ratings to 1200A continuous bus, 900A continuous and switching ways are available on certain models
- Single side access designs are available for confined space applications

Operator Safety offers:

- Switches are totally sealed, dead front and insulated with non-flammable, nontoxic gas.
- Operators are spring assisted for positive quick-make, quick-break operation
- Trip-free mechanism permits interruption independent of the operating handle if closing into a fault
- Viewing windows permit visible indication of interrupter contact position.

Minimal Maintenance

- No more routine inspections or dielectric testing
- No more contact contamination, rodent problems or insulator maintenance
- A periodic check of the gas pressure gauge is all that is required.

Three Phase Tripping

- Simultaneous three phase tripping is available through the electronics and with three phase operating handles for manual operation and reset

Protection Curve Compatibility offers:

- Solid state electronic controls permit extremely accurate, consistent protection curve characteristics
- Controls can emulate the most common time current curves (TCC) for power fuses, relays and fuse links
- Optional electronic packages can provide ground trip, inrush restraint and adjustable time delay capability

Fully Tested

- Switches are designed and tested per applicable sections of IEEE C37.71, C37.60, C37.74 and IEC 265 standards

Applications

G&W Electric combination switches provide a direct replacement for power fused air and vacuum-in-oil switchgear. Some ideal applications include:

Transformer and Motor Protection

- The three phase trip feature and high continuous current capability protects three phase motors and transformers.

Loop and Tap Switching

- Tap switching up to 900A and up to 25kA symmetric fault protection is accomplished using resettable, electronically controlled vacuum interrupters. The vacuum interrupters also function as load break switches.

Automatic Transfer for Critical Load Applications

- Switches can be supplied with an automatic transfer control package to provide automatic transfer from one source to another minimizing downtime

Smart Grid / Lazer Solutions

- Can be supplied with motor actuators on both the line and load side providing remote control capability
- For Smart Grid applications, we work with the top control manufacturers of the industry, to match the right control for the application
- For automatic power restoration, G&W's Lazer solution provides a pre-engineered, field proven system which can be pre-assembled and factory tested prior to shipment
- Various control packages including portable controls are available

Metal clad Switchgear Replacement

- Front access designs can provide up to a 1200A rated main bus with up to six 25kA symmetric

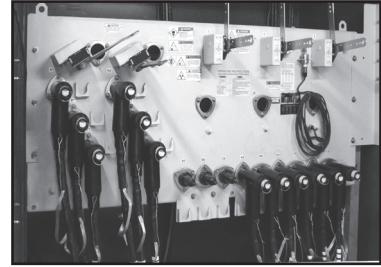

VPNI single side access switch

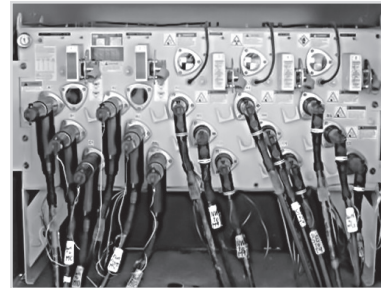

VPNI41 with rotary style operator.

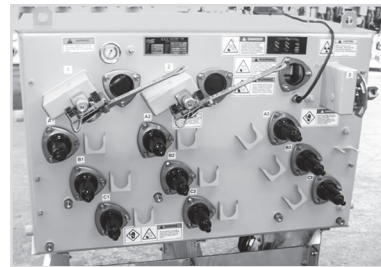

Model VLPI32

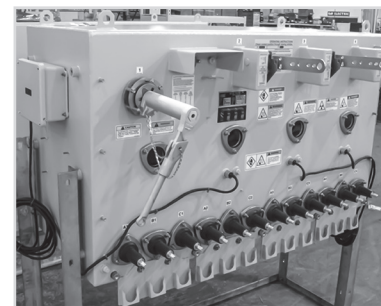

Model VPNI-9F

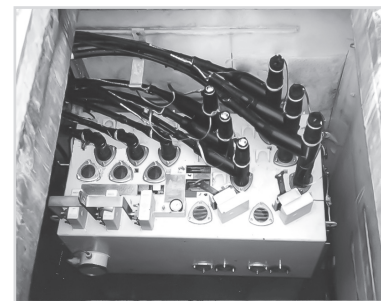

Model VPVI-6F

Load and Fault Interrupting Switches

Two Position, Front Access Puffer Vacuum Interrupters

Rotary Puffer (VRPFI) Diagonal bushing configurations. Provides smallest footprint with three phase fault interrupting.

Load break switch (RP) ratings		
Maximum Design Voltage kV	15.5	27
Voltage class, kV	15	25
Impulse level (BIL), kV	110	125
One minute withstand, AC kV	35	60
One minute withstand, Production test rating, AC kV	34	40
15 minute withstand, DC kV	53	78
Continuous and load break current, Amps	630	630
Momentary current, kA asym	25.6	20
Fault-close current, (3 times) kA asym	25.6	20
One second current, kA sym	16	12.5
Operations load interrupting endurance (15kV) at 600A	500	350
Mechanical endurance, operations	2000	2000
Fault interrupter (FI) ratings		
Maximum Design Voltage kV	15.5	27
Voltage class, kV	15	25
Impulse level (BIL), kV	110	125
One minute withstand, AC kV	50	60
One minute withstand, Production test rating, AC kV	34	40
15 minute withstand, DC kV	53	78
Continuous and load break current, Amps	630	630
Symmetrical interrupting rating, kA	12.5*	12.5

*16kA available upon request

IEEE C37.60 Fault Interrupting Duty for 12.5kA specified models

Total number of fault interruptions: 116		
Percent of Maximum Interrupting Rating	Approx. Interrupting Current, Amps	No. of Fault Interruptions
15-20%	2,000	44
45-55%	6,000	56
90-100%	12,500	16

Load and Fault Interrupting Switches con't

Two Position, Front Access, Puffer Vacuum Interrupters con't

Linear Puffer (VLPFI)

Provides load break switch with visible break and three phase fault interrupting.

Load break switch (LP) ratings			
Maximum Design Voltage kV	15.5	27	38
Voltage class, kV	15	25	35
Impulse level (BIL), kV	110	125	150
One minute withstand, AC kV	35	60	70
One minute withstand, Production test rating, AC kV	34	40	50
15 minute withstand, DC kV	53	78	103
Continuous and load break current, Amps	630	630	630
Momentary current, kA asym	40	40	40
Fault-close current, (3 times) kA asym	40	40	40
One second current, kA sym	25	25	25
Open gap withstand, kV	200	200	200
10 operation overload interrupting capability,Amps	3000	3000	3000
Operations load interrupting endurance (15kV) at 600A	1200	1200	1200
Mechanical endurance, operations	2000	2000	2000
Fault interrupter (FI) ratings			
Maximum Design Voltage kV	15.5	27	
Voltage class, kV	15	25	
Impulse level (BIL), kV	110	125	
One minute withstand, AC kV	50	60	
One minute withstand, Production test rating, AC kV	34	40	
15 minute withstand, DC kV	53	78	
Continuous and load break current, Amps	630	630	
Symmetrical interrupting rating, kA	12.5*	12.5	

*16kA available upon request at 15kV

IEEE C37.60 Fault Interrupting Duty for 12.5kA specified models

Total number of fault interruptions: 116		
Percent of Maximum Interrupting Rating	Approx. Interrupting Current, Amps	No. of Fault Interruptions
15-20%	2,000	44
45-55%	6,000	56
90-100%	12,500	16

Two Position, Front Access, Puffer Vacuum Interrupters

Linear Puffer (VPNI)

Provides load break switch visible break with 25kA symmetrical three phase interrupting

Load break switch (LP) ratings			
Maximum Design Voltage kV	15.5	27	38
Voltage class, kV	15	25	35
Impulse level (BIL), kV	110	125	150
One minute withstand, AC kV	35	60	70
One minute withstand, Production test rating, AC kV	34	40	50
15 minute withstand, DC kV	53	78	103
Continuous and load break current, Amps ¹	630 or 900	630 or 900	630 or 900
Momentary current, kA asym	40	40	40
Fault-close current, (3 times) kA asym	40	40	40
One second current, kA sym	25	25	25
Open gap withstand, kV	200	200	200
10 operation overload interrupting capability, Amps	3000	3000	3000
Operations load interrupting endurance (15kV) at 600A	1200	1200	1200
Mechanical endurance, operations	2000	2000	2000
Fault interrupter (NI) ratings			
Maximum Design Voltage kV	15.5	27	38
Voltage class, kV	15	25	35
Impulse level (BIL), kV	110	125	150
One minute withstand, AC kV	50	60	70
One minute withstand, Production test rating, AC kV	34	40	50
15 minute withstand, DC kV	53	78	103
Continuous and load break current, Amps ¹	630 or 900	630 or 900	630 or 900
Symmetrical interrupting rating, kA*	25	25	25

¹ Available with 630A or 900A continuous and load break current on bus and switches

*Available 12.5kA, 20kA or 25kA sym.

IEEE C37.60 Fault Interrupting Duty for 25kA specified models

Total number of fault interruptions: 116		
Percent of Maximum Interrupting Rating	Approx. Interrupting Current, Amps	No. of Fault Interruptions
15-20%	5,000	44
45-55%	12,500	56
90-100%	25,000	16

Two Position, Front Access, Puffer Vacuum Interrupters

Linear Puffer ((VPVI))

Provides load break switch visible break and single phase or three phase fault interrupting. Fault interrupters can be changed from single phase to three phase operation in the field.

Load break switch (LP) ratings			
Maximum Design Voltage kV	15.5	27	38
Voltage class, kV	15	25	35
Impulse level (BIL), kV	110	125	150
One minute withstand, AC kV	35	60	70
One minute withstand, Production test rating, AC kV	34	40	50
15 minute withstand, DC kV	53	78	103
Continuous and load break current, Amps* (<i>*900A continuous available.</i>)	630	630	630
Momentary current, kA asym	40	40	40
Fault-close current, (3 times) kA asym	40	40	40
One second current, kA sym	25	25	25
Open gap withstand, kV	200	200	200
10 operation overload interrupting capability, Amps	3000	3000	3000
Operations load interrupting endurance (15kV) at 600A	1200	1200	1200
Mechanical endurance, operations	2000	2000	2000
Fault interrupter (VI) ratings			
Maximum Design Voltage kV	15.5	27	38
Voltage class, kV	15	25	35
Impulse level (BIL), kV	95	125	150
One minute withstand, AC kV	50	60	70
One minute withstand, Production test rating, AC kV	34	40	50
15 minute withstand, DC kV	53	78	103
Continuous and load break current, Amps	630	630	630
Symmetrical interrupting rating, kA** (<i>**20kA available</i>)	12	12	12

IEEE C37.60 Fault Interrupting Duty for 12kA specified models

Total number of fault interruptions: 116		
Percent of Maximum Interrupting Rating	Approx. Interrupting Current, Amps	No. of Fault Interruptions
15-20%	2,000	44
45-55%	6,000	56
90-100%	12,000	16



Switch Styles	Height	Depth
VRPFI styles:	29.5" (749mm)	22.4" (569mm)
VLRFI styles	31" (787mm)	28" (711mm)

Switch Styles	Heights	Depth
VPNI styles:	38" (965mm)	27" (686mm)
VPVI styles 38kV:	38" (965mm)	31" (787mm)
VPVI styles 15kV and 27kV:	33" (838mm)	31" (787mm)

Two Position, Front Access, Puffer Vacuum Interrupters

Model	One-line Diagram	Voltage kV	Catalog Number	Width in. (mm)	Weight w/Gas lbs. (kgs)		
4F		15	VPNI20-376-25-4F	43 (1092)	1050 (477)		
			VPFI20-376-12-4F	38.1 (969)	800 (363)		
			VPVI20-376-12-4F	26 (660)	1100 (500)		
		25	VPNI20-386-25-4F	43 (1092)	1050 (477)		
			VPFI20-386-12-4F	38.1 (969)	800 (363)		
			VPVI20-386-12-4F	26 (660)	1100 (500)		
		35	VPNI20-396-12-4F	43 (1092)	1050 (477)		
			VPVI20-396-12-4F	35 (889)	1100 (500)		
		5F		15	VRPFI21-376-12-5F	32 (813)	800 (363)
VLPI21-376-12-5F	45 (1149)				1025 (466)		
VPNI21-376-25-5F	43 (1092)				1100 (500)		
VPVI21-376-12-5F	50.5 (1283)				1100 (500)		
25	VRPFI21-386-12-5F			32 (813)	1025 (466)		
	VLPI21-386-12-5F			45 (1149)	1100 (500)		
	VPNI21-386-25-5F			43 (1092)	1100 (500)		
	VPVI21-386-12-5F			50.5 (1283)	1100 (500)		
35	VPNI21-396-12-5F			43 (1092)	1100 (500)		
	VPVI21-396-12-5F			59.5 (1511)	1210 (550)		
6F				15	VRPFI32-376-12-6F	44 (1118)	1000 (454)
					VLPI32-376-12-6F	57.5 (1467)	1250 (568)
		VPNI32-376-25-6F	58 (1473)		1300 (591)		
		VPVI32-376-12-6F	63 (1600)		1300 (591)		
		25	VRPFI32-386-12-6F	44 (1118)	1000 (454)		
			VLPI32-386-12-6F	57.5 (1467)	1250 (568)		
			VPNI32-386-25-6F	58 (1473)	1300 (591)		
			VPVI32-386-12-6F	63 (1600)	1300 (591)		
		35	VPNI32-396-12-6F	58 (1473)	1300 (591)		
			VPVI32-396-12-6F	72 (1829)	1500 (682)		
		7F		15	VRPFI31-376-12-7F	44 (1118)	1100 (499)
					VLPI31-376-12-7F	57 (1454)	1300 (591)
VPNI31-376-25-7F	58 (1473)				1400 (636)		
VPVI31-376-12-7F	71.5 (1816)				1500 (682)		
25	VRPFI31-386-12-7F			44 (1118)	1100 (499)		
	VLPI31-386-12-7F			57 (1454)	1300 (591)		
	VPNI31-386-25-7F			58 (1473)	1400 (636)		
	VPVI31-386-12-7F			71.5 (1816)	1500 (682)		
35	VPNI31-396-12-7F			58 (1473)	1400 (636)		
	VPVI31-396-12-7F			89.5 (2273)	1800 (818)		

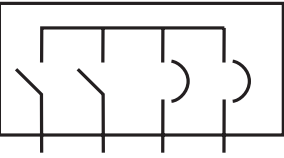
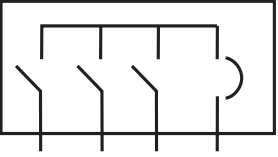
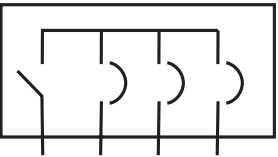
Two Position, Front Access, Puffer Vacuum Interrupters

Model	One-line Diagram	Voltage kV	Catalog Number	Width in. (mm)	Weight w/Gas lbs. (kgs)
9F		15	VRPFI42-376-12-9F	56 (1422)	1200 (545)
			VL PFI42-376-12-9F	69.5 (1772)	1350 (614)
			VPNI42-376-25-9F	73 (1854)	1550 (705)
			VPVI42-376-12-9F	84 (2134)	1700 (773)
		25	VRPFI42-386-12-9F	56 (1422)	1200 (545)
			VL PFI42-386-12-9F	69.5 (1772)	1350 (614)
			VPNI42-386-25-9F	73 (1854)	1550 (705)
			VPVI42-386-12-9F	84 (2134)	1700 (773)
		35	VPNI42-396-12-9F	73 (1854)	1550 (705)
			VPVI42-396-12-9F	102 (2591)	1950 (886)
11F		15	VRPFI43-376-12-11F	56 (1422)	1200 (545)
			VL PFI43-376-12-11F	70 (1784)	1325 (602)
			VPNI43-376-25-11F	73 (1854)	1650 (750)
			VPVI43-376-12-11F	75.5 (1918)	1600 (727)
		25	VRPFI43-386-12-11F	56 (1422)	1200 (545)
			VL PFI43-386-12-11F	70 (1784)	1325 (602)
			VPNI43-386-25-11F	73 (1854)	1650 (750)
			VPVI43-386-12-11F	75.5 (1918)	1600 (727)
		35	VPNI43-396-12-11F	73 (1854)	1650 (750)
			VPVI43-396-12-11F	84.5 (2146)	1750 (795)
12F		15	VRPFI41-376-12-12F	56 (1422)	1200 (545)
			VL PFI41-376-12-12F	69 (1759)	1400 (636)
			VPNI41-376-25-12F	73 (1854)	1650 (750)
			VPVI41-376-12-12F	92.5 (2350)	1850 (841)
		25	VRPFI41-386-12-12F	56 (1422)	1200 (545)
			VL PFI41-386-12-12F	69 (1759)	1400 (636)
			VPNI41-386-25-12F	73 (1854)	1650 (750)
			VPVI41-386-12-12F	92.5 (2350)	1850 (841)
		35	VPNI41-396-12-12F	73 (1854)	1650 (750)
			VPVI41-396-12-12F	119.5 (3035)	2100 (955)
43F	 <i>Bus Tie</i>	15	VRPFI43-376-12-43F-BT	68 (1727)	1450 (658)
			VL PFI43-376-12-43F-BT	89 (2261)	1800 (818)
			VPNI43-376-25-43F-BT	88 (2235)	1850 (839)
			VPVI43-376-12-43F-BT	105.3 (2675)	1900 (862)
		25	VRPFI43-386-12-43F-BT	68 (1727)	1450 (658)
			VL PFI43-386-12-43F-BT	89 (2261)	1800 (818)
			VPNI43-386-25-43F-BT	88 (2235)	1850 (839)
			VPVI43-386-12-43F-BT	105.3 (2675)	1900 (862)
		35	VPNI43-396-12-43F-BT	88 (2235)	1850 (839)

TWO POSITION, FRONT ACCESS, PUFFER VACUUM INTERRUPTERS

Model	One-line Diagram	Voltage kV	Catalog Number	Width in. (mm)	Weight w/Gas lbs. (kgs)
51F		15	VRPFI51-376-12-51F	68 (1727)	1650 (749)
			VLPI51-376-12-51F	81 (2064)	1950 (886)
			VPNI51-376-25-51F	88 (2235)	2000 (909)
			VPVI51-376-12-51F	113.5 (2883)	2250 (1023)
		25	VRPFI51-386-12-51F	68 (1727)	1650 (749)
			VLPI51-386-12-51F	81 (2064)	1950 (886)
			VPNI51-386-25-51F	88 (2235)	2000 (909)
			VPVI51-386-12-51F	113.5 (2883)	2250 (1023)
		35	VPNI51-396-12-51F	88 (2235)	2000 (909)
			VPVI51-396-12-51F	149.5 (3797)	2650 (1205)
52F		15	VRPFI52-376-12-52F	68 (1727)	1450 (658)
			VLPI52-376-12-52F	81.5 (2076)	1875 (852)
			VPNI52-376-25-52F	88 (2235)	1900 (864)
			VPVI52-376-12-52F	105 (2667)	2100 (955)
		25	VRPFI52-386-12-52F	68 (1727)	1450 (658)
			VLPI52-386-12-52F	81.5 (2076)	1875 (852)
			VPNI52-386-25-52F	88 (2235)	1900 (864)
			VPVI52-386-12-52F	105 (2667)	2100 (955)
		35	VPNI52-396-12-52F	88 (2235)	1900 (864)
			VPVI52-396-12-52F	132 (3353)	2400 (1089)
53F		15	VRPFI53-376-12-53F	68 (1727)	1450 (658)
			VLPI53-376-12-53F	82 (2089)	1800 (818)
			VPNI53-376-25-53F	88 (2235)	1850 (839)
			VPVI53-376-12-53F	96.5 (2451)	1900 (862)
		25	VRPFI53-386-12-53F	68 (1727)	1450 (658)
			VLPI53-386-12-53F	82 (2089)	1800 (818)
			VPNI53-386-25-53F	88 (2235)	1850 (839)
			VPVI53-386-12-53F	96.5 (2451)	1900 (862)
		35	VPNI53-396-12-53F	88 (2235)	1850 (839)
			VPVI53-396-12-53F	114.5 (2908)	2200 (998)
54F		15	VRPFI54-376-12-54F	68 (1727)	1350 (613)
			VLPI54-376-12-54F	82.5 (2102)	1750 (795)
			VPNI54-376-25-54F	88 (2235)	1800 (818)
			VPVI54-376-12-54F	87 (2210)	1800 (818)
		25	VRPFI54-386-12-54F	68 (1727)	1350 (613)
			VLPI54-386-12-54F	82.5 (2102)	1750 (795)
			VPNI54-386-25-54F	88 (2235)	1800 (818)
			VPVI54-386-12-54F	87 (2210)	1800 (818)
		35	VPNI54-396-12-54F	88 (2235)	1800 (818)
			VPVI54-396-12-54F	96 (2438)	2000 (907)

TWO POSITION, FRONT ACCESS, PUFFER VACUUM INTERRUPTERS

Model	One-line Diagram	Voltage kV	Catalog Number	Width in. (mm)	Weight w/Gas lbs. (kgs)
62F		15	VRPFI62-376-12-62F	80 (2032)	1650 (749)
			VLPI62-376-12-62F	93.5 (2381)	2000 (909)
			VPNI62-376-25-62F	103 (2616)	2300 (1043)
			VPVI62-376-12-62F	126 (3200)	2500 (1134)
		25	VRPFI62-386-12-62F	80 (2032)	1650 (749)
			VLPI62-386-12-62F	93.5 (2381)	2000 (909)
			VPNI62-386-25-62F	103 (2616)	2300 (1043)
			VPVI62-386-12-62F	126 (3200)	2500 (1134)
		35	VPNI62-396-12-62F	103 (2616)	2300 (1043)
		63F		15	VRPFI63-376-12-63F
VLPI63-376-12-63F	94 (2394)				1950 (886)
VPNI63-376-25-63F	103 (2616)				2200 (998)
VPVI63-376-12-63F	117.5 (2985)				2300 (1043)
25	VRPFI63-386-12-63F			80 (2032)	1650 (749)
	VLPI63-386-12-63F			94 (2394)	1950 (886)
	VPNI63-386-25-63F			103 (2616)	2200 (998)
	VPVI63-386-12-63F			117.5 (2985)	2300 (1043)
35	VPNI63-396-12-63F			103 (2616)	2200 (998)
	VPVI63-396-12-63F			144.5 (3670)	2700 (1225)
64F		15	VRPFI64-376-12-64F	80 (2032)	1550 (704)
			VLPI64-376-12-64F	94.5 (2407)	1900 (864)
			VPNI64-376-25-64F	103 (2616)	2100 (955)
			VPVI64-376-12-64F	109 (2769)	2200 (998)
		25	VRPFI64-386-12-64F	80 (2032)	1550 (704)
			VLPI64-386-12-64F	94.5 (2407)	1900 (864)
			VPNI64-386-25-64F	103 (2616)	2100 (955)
			VPVI64-386-12-64F	109 (2769)	2200 (998)
		35	VPNI64-396-12-64F	103 (2616)	2100 (955)
			VPVI64-396-12-64F	127 (3226)	2400 (1089)
65F		15	VRPFI65-376-12-65F	80 (2032)	1550 (704)
			VLPI65-376-12-65F	95 (2419)	1850 (841)
			VPNI65-376-25-65F	103 (2616)	2000 (907)
			VPVI65-376-12-65F	99.5 (2527)	2100 (955)
		25	VRPFI65-386-12-65F	80 (2032)	1550 (704)
			VLPI65-386-12-65F	95 (2419)	1850 (841)
			VPNI65-386-25-65F	103 (2616)	2000 (907)
			VPVI65-386-12-65F	99.5 (2527)	2100 (955)
		35	VPNI65-396-12-65F	103 (2616)	2000 (907)
			VPVI65-396-12-65F	108.5 (2756)	2200 (998)

TWO POSITION, FRONT ACCESS, PUFFER VACUUM INTERRUPTERS

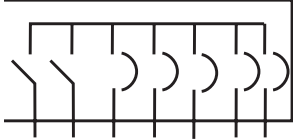
Model	One-line Diagram	Voltage kV	Catalog Number	Width in. (mm)	Weight w/Gas lbs. (kgs)
72F		15	VRPFI72-376-12-72F	92 (2337)	1500 (682)
			VLPFI72-376-12-72F	105.5 (2680)	2000 (909)
			VPNI72-376-25-72F	118 (2997)	2600 (1182)
			VPVI72-376-12-72F	147 (3734)	2800 (1273)
		25	VRPFI72-386-12-72F	92 (2337)	1500 (682)
			VLPFI72-386-12-72F	105.5 (2680)	2000 (909)
			VPNI72-386-25-72F	118 (2997)	2600 (1182)
			VPVI72-386-12-72F	147 (3734)	2800 (1273)
35	VPNI72-396-12-72F	118 (2997)	2600 (1182)		

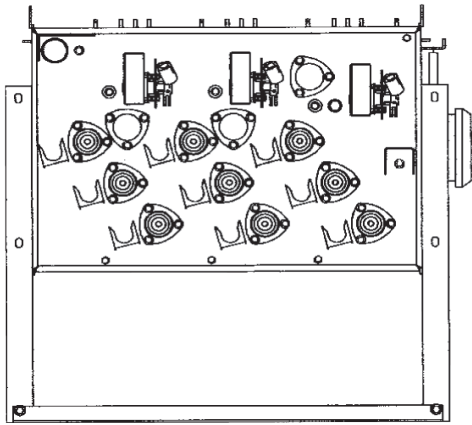

Manually operated VRPFI-6F shown.

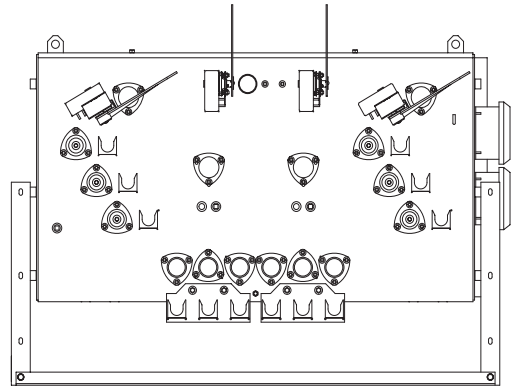

Model VPNI-9F Shown with diagonal bushing configuration.

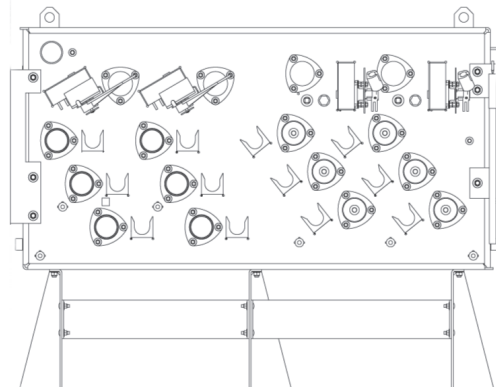

Model VPVI-6F shown.

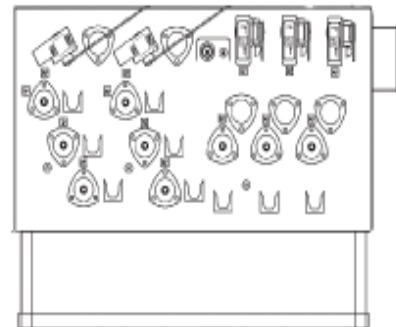

Manually operated VLPFI-9F shown.

Load and Fault Interrupting Switches

Three Position, Front Access, TFI with Load Break Ground Switches

These switches incorporate rotary puffer style internal ground for the load break switch ways. Two models offer different ratings and vacuum interrupter capabilities as follows:

- **Model VTFI:** Provides three phase protection.
- **Model VTFI:** Provides single phase or three phase protection with 12 or 20kA symmetrical interrupting.

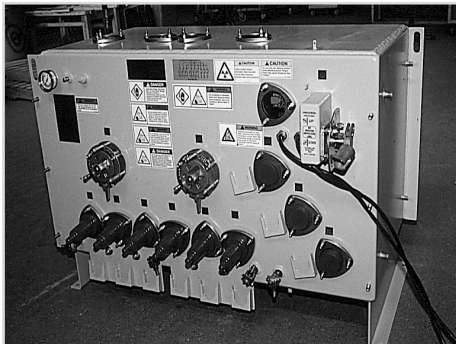

Model VTFI



Model VTFI:

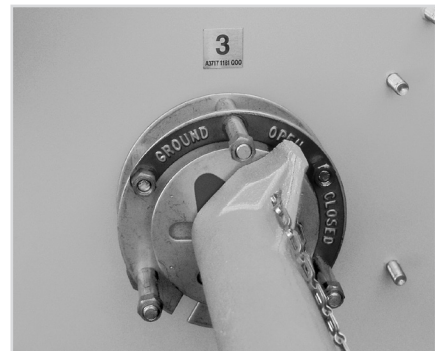

Load break multi-position switch operator

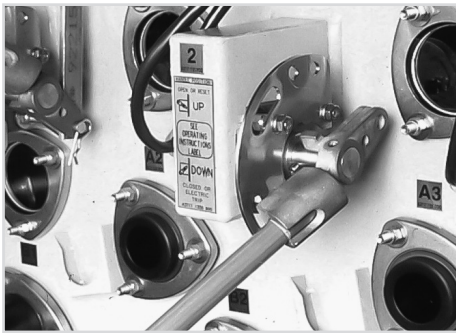

Fault interrupter operating handle



Single phase interrupter operating handles



Three phase interrupter operating handle

Three Position, Front Access, TFI with Load Break Ground Switches

Switches incorporate rotary puffer style internal ground for the load break switch ways. Two models offer different ratings and vacuum interrupter capabilities as follows: Model VTFI Provides three phase protection.

Load break switch (RP) ratings		
Maximum Design Voltage kV	15.5	27
Voltage class, kV	15	25
Impulse level (BIL), kV	110	125
One minute withstand, AC kV	35	60
One minute withstand, Production test rating, AC kV	34	40
15 minute withstand, DC kV	53	78
Continuous and load break current, Amps	630	630
Momentary current, kA asym	40	40
Fault-close current, (3 times) kA asym	32	32
One second current, kA sym	25	25
Mechanical endurance, operations	2000	2000
Fault interrupter (FI) ratings		
Maximum Design Voltage kV	15.5	27
Voltage class, kV	15	25
Impulse level (BIL), kV	110	125
One minute withstand, AC kV	50	60
One minute withstand, Production test rating, AC kV	34	40
15 minute withstand, DC kV	53	78
Continuous and load break current, Amps	630	630
Symmetrical interrupting rating, kA)	12.5*	12.5

*16kA available upon request at 15kV

IEEE C37.60 Fault Interrupting Duty

Total number of fault interruptions: 116		
Percent of Maximum Interrupting Rating	Approx. Interrupting Current, Amps	No. of Fault Interruptions
15-20%	2,000	44
45-55%	6,000	56
90-100%	12,500	16

Three Position, Front Access, TFI with Load Break Ground Switches

Switches incorporate rotary puffer style internal ground for the load break switch ways. Two models offer different ratings and vacuum interrupter capabilities as follows: Model VTVI Provides single phase or three phase protection with 12 or 20kA symmetrical interrupting.

Load break switch (RP) ratings			
Maximum Design Voltage kV	15.5	27	38
Voltage class, kV	15	25	35
Impulse level (BIL), kV	110	125	150
One minute withstand, AC kV	35	60	70
One minute withstand, Production test rating, AC kV	34	40	50
15 minute withstand, DC kV	53	78	103
Continuous and load break current, Amps	630	630	630
Momentary current, kA asym	40	40	40
Fault-close current, (3 times) kA asym	32	32	32
One second current, kA sym	25	25	25
Mechanical endurance, operations	2000	2000	2000
Fault interrupter (VI) ratings			
Maximum Design Voltage kV	15.5	27	38
Voltage class, kV	15	25	35
Impulse level (BIL), kV	95	125	150
One minute withstand, AC kV	50	60	70
One minute withstand, Production test rating, AC kV	34	40	50
15 minute withstand, DC kV	53	78	103
Continuous and load break current, Amps	630	630	630
Symmetrical interrupting rating, kA (20kA available)	12	12	12

IEEE C37.60 Fault Interrupting Duty for 12kA specified models

Total number of fault interruptions: 116		
Percent of Maximum Interrupting Rating	Approx. Interrupting Current, Amps	No. of Fault Interruptions
15-20%	2,000	44
45-55%	6,000	56
90-100%	12,000	16

Load and Fault Interrupting Switches

Three Position, Front / Back Access, TNI with Both Load Break and Fault Interrupter Ground Switches

Switches incorporate rotary puffer style internal ground switching for both the load break and fault interrupter switch ways. Model NI vacuum interrupter three phase mechanisms are used.

Load break switch (RP) ratings			
Maximum Design Voltage kV	15.5	27	38
Voltage class, kV	15	25	35
Impulse level (BIL), kV	110	125	150
One minute withstand, AC kV	35	60	70
One minute withstand, Production test rating, AC kV	34	40	50
15 minute withstand, DC kV	53	78	103
Continuous and load break current, Amps	630	630	630
Momentary current, kA asym	40	40	40
Fault-close current, (3 times) kA asym	32	32	32
One second current, kA sym	25	25	25
Mechanical endurance, operations	2000	2000	2000
Fault interrupter (NI) ratings			
Maximum Design Voltage kV	15.5	27	38
Voltage class, kV	15	25	35
Impulse level (BIL), kV	110	125	150
One minute withstand, AC kV	50	60	70
One minute withstand, Production test rating, AC kV	34	40	50
15 minute withstand, DC kV	53	78	103
Continuous and load break current, Amps	630	630	630
Symmetrical interrupting rating, kA (20kA or 25kA available)	12.5	12.5	12.5

IEEE C37.60 Fault Interrupting Duty for 25kA specified models

Total number of fault interruptions: 116		
Percent of Maximum Interrupting Rating	Approx. Interrupting Current, Amps	No. of Fault Interruptions
15-20%	5,000	44
45-55%	12,500	56
90-100%	25,000	16



Front view of a TNI-9L



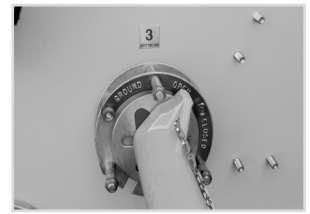

Cable entrances are located on the back of the switch.



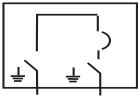
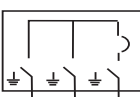
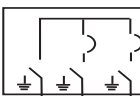
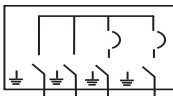

Load break multi-position switch operator

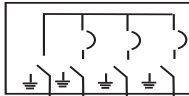
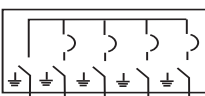
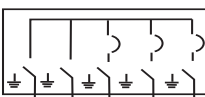
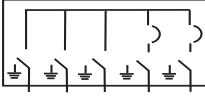
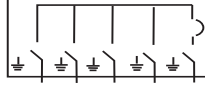
Three Position, Front / Back Access, TNI with Both Load Break and Fault Interrupter Ground Switches

Model	One-line Diagram	Voltage kV	Catalog Number	Width in. (mm)	Weight w/Gas lbs. (kgs)
5		15	VTNI21-376-12-5L	46 (1168)	1115 (507)
		25	VTNI21-386-12-5L	46 (1168)	1115 (507)
		35	VTNI21-396-12-5L	46 (1168)	1115 (507)
6		15	VTNI32-376-12-6L	65 (1651)	1885 (857)
		25	VTNI32-386-12-6L	65 (1651)	1885 (857)
		35	VTNI32-396-12-6L	65 (1651)	1885 (857)
7		15	VTNI31-376-12-7L	65 (1651)	1960 (891)
		25	VTNI31-386-12-7L	65 (1651)	1960 (891)
		35	VTNI31-396-12-7L	65 (1651)	1960 (891)
9		15	VTNI42-376-12-9L	88 (2235)	2360 (1073)
		25	VTNI42-386-12-9L	88 (2235)	2360 (1073)
		35	VTNI42-396-12-9L	88 (2235)	2360 (1073)
11		15	VTNI43-376-12-11L	83 (2108)	2285 (1039)
		25	VTNI43-386-12-11L	83 (2108)	2285 (1039)
		35	VTNI43-386-12-11L	83 (2108)	2285 (1039)
12		15	VTNI41-376-12-12L	83 (2108)	2435 (1107)
		25	VTNI41-386-12-12L	83 (2108)	2435 (1107)
		35	VTNI41-396-12-12L	83 (2108)	2435 (1107)
51		15	VTNI51-376-12-51L	101 (2565)	2930 (1332)
		25	VTNI51-386-12-51L	101 (2565)	2930 (1332)
		35	VTNI51-396-12-51L	101 (2565)	2930 (1332)
52		15	VTNI52-376-12-52L	101 (2565)	2855 (1311)
		25	VTNI52-386-12-52L	101 (2565)	2855 (1311)
		35	VTNI52-396-12-52L	101 (2565)	2855 (1311)
53		15	VTNI53-376-12-53L	101 (2565)	2780 (1264)
		25	VTNI53-386-12-53L	101 (2565)	2780 (1264)
		35	VTNI53-396-12-53L	101 (2565)	2780 (1264)
54		15	VTNI54-376-12-54L	101 (2565)	2705 (1230)
		25	VTNI54-386-12-54L	101 (2565)	2705 (1230)
		35	VTNI54-396-12-54L	101 (2565)	2705 (1230)

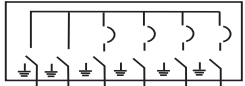
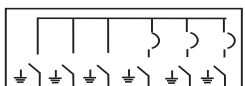
Three Position, Front / Back Access, TNI with Both Load Break and Fault Interrupter Ground Switches

62		15	VTNI62-376-12-62L	119 (3023)	2430 (1105)
		25	VTNI62-386-12-62L	119 (3023)	2430 (1105)
		35	VTNI62-396-12-62L	119 (3023)	2430 (1105)
63		15	VTNI63-376-12-63L	119 (3023)	2355 (1070)
		25	VTNI63-386-12-63L	119 (3023)	2355 (1070)
		35	VTNI63-396-12-63L	119 (3023)	2355 (1070)
64		15	VTNI64-376-12-64L	119 (3023)	2280 (1036)
		25	VTNI64-386-12-64L	119 (3023)	2280 (1036)
		35	VTNI64-396-12-64L	119 (3023)	2280 (1036)
65		15	VTNI65-376-12-65L	119 (3023)	2205 (1002)
		25	VTNI65-386-12-65L	119 (3023)	2205 (1002)
		35	VTNI65-396-12-65L	119 (3023)	2205 (1002)

All voltage classes have a height = 42.5" (1080mm); depth = 36" (914mm).
For typical specifications, go to: gwelec.com/specs.html

For contact principles, see pages 28 and 32.
Dimensions are approximate.
Do not use for construction.

Two Position Load Break, Rectangular Tank Style, RAM Series

Available in 20kA (Rotary Puffer) and 40kA (Linear Puffer) designs.

RAM styles incorporate in-line bushing arrangements with a 5" phase spacing. Bushings can be top, bottom, front or side mounted.

SRAM styles provide the most compact construction due to diagonal bushing arrangements with a 6-1/2" phase spacing. These models can accommodate bushing mounted fuses.

Linear Puffer (PI) ratings			
Maximum Design Voltage kV	15	27	38
Voltage class, kV	15	25	35
Impulse level (BIL), kV	110	125	150
One minute withstand, AC kV	35	60	70
One minute withstand, Production test rating, AC kV	34	40	50
15 minute withstand, DC kV	53	78	103
Continuous and load break current, Amps*	630	630	630
Momentary current, kA asym	40	40	40
Fault-close current, (3 times) kA asym	40	40	40
One second current, kA sym	25	25	25
Open gap withstand, kV	200	200	200
10 operation overload interrupting capability, A	3000	3000	3000
Operations load interrupting at 600A	1200	1200	1200
Mechanical endurance, operations	2000	2000	2000

*900A available

Two Position Load Break Switches

Variety of styles available. Bushings can be front, top, bottom or side mounted.

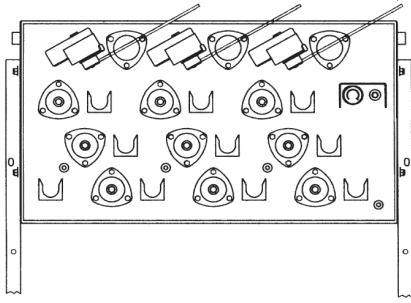

SRAM with front mounted bushings and operators.

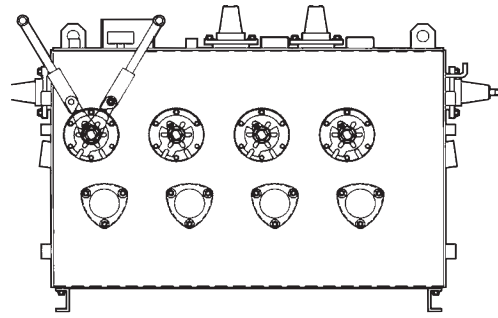

VRAM with top mounted bushings and operators.

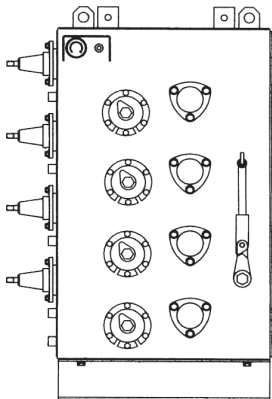

Vertical mount VRAM44 with side mounted bushings and front operators.

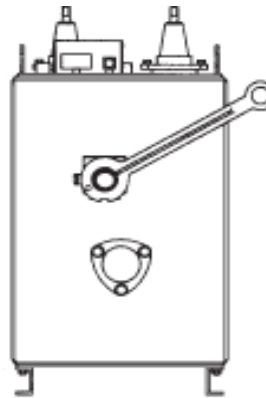

VRAM with top mounted bushings and front operator.

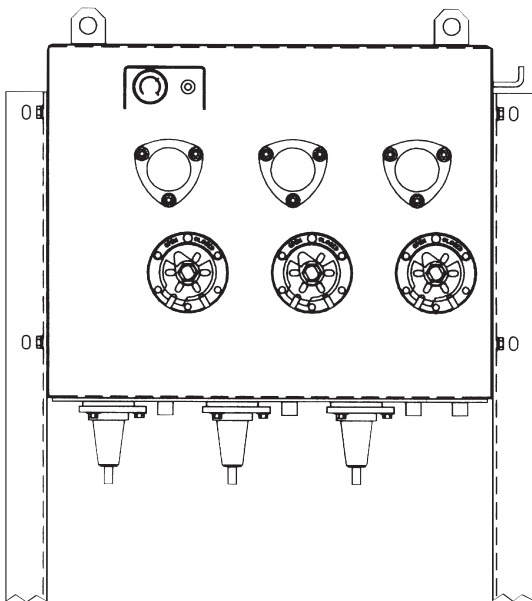

RAM Series - front view

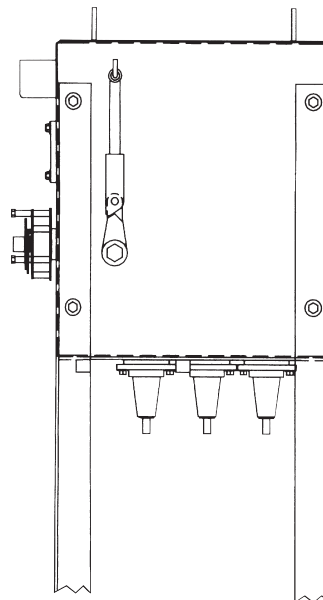

RAM Series - side view

Two Position Load Break Switches

RPR / RPL / RPRM Series

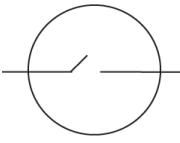
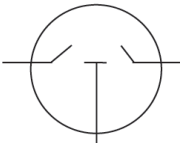
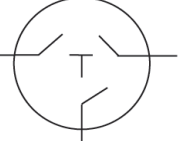
One-line Diagram	Voltage kV	Number of phases	Catalog Number	(A) Width in. (mm)	(B) Height in. (mm)	Weight w/Gas lbs. (kgs)
	15	1	15RPR1W	29 (737)	31 (787)	250 (114)
		2	15RPR2W	29 (737)	31 (787)	275 (125)
		3	15RPR3W	29 (737)	31 (787)	300 (136)
	25	1	27RPR1W	29 (737)	31 (787)	250 (114)
		2	27RPR2W	29 (737)	31 (787)	275 (125)
		3	27RPR3W	29 (737)	31 (787)	300 (136)
	15	1	15RPL1W	29 (737)	31 (787)	250 (114)
		2	15RPL2W	29 (737)	31 (787)	275 (125)
		3	15RPL3W	29 (737)	31 (787)	300 (136)
	25	1	27RPL1W	29 (737)	31 (787)	250 (114)
		2	27RPL2W	29 (737)	31 (787)	275 (125)
		3	27RPL3W	29 (737)	31 (787)	300 (136)
	15	1	15RPRM1W	35 (889)	31 (787)	300 (136)
		2	15RPRM2W	35 (889)	31 (787)	325 (148)
		3	15RPRM3W	35 (889)	31 (787)	350 (159)
	25	1	27RPRM1W	35 (889)	31 (787)	300 (136)
		2	27RPRM2W	35 (889)	31 (787)	325 (148)
		3	27RPRM3W	35 (889)	31 (787)	350 (159)

For PI, RAM designs: depth = 30" (762), height = 26" (660mm). RAM catalog numbers with bottom bushings shown. For typical specifications, go to gwelec.com/specs.html. For contact principles, see pages 30 and 31. Dimensions are approximate. Do not use for construction.

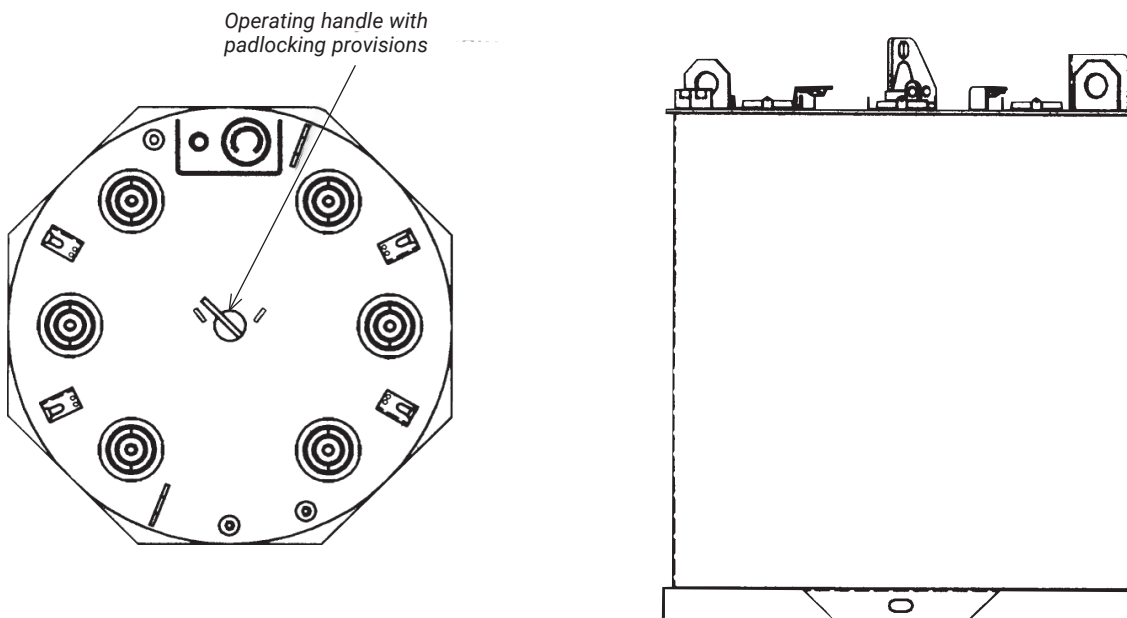

Three Position Load Break Switches

Three Position, Ground Switches - GRAM series (Close-Open-Ground)

An integral ground position within the switch tank permits safe and easy grounding of the cable circuit without having to disconnect elbow or other cable entrance connections. Switching to ground is accomplished through the simple throw of the operating handle without having to de-energize other circuits through the switch. This feature is beneficial for applications using lead covered cables where cable movement needs to be minimized. Ground stops with padlocking provisions help assure proper operation in the desired position.

Rotary Puffer (RP) Ratings			
Maximum Design Voltage kV	15.5	27	38
Voltage class, kV	15	25	35
Impulse level (BIL), kV	110	125	150
One minute withstand, AC kV	35	60	70
One minute withstand, Production test rating, AC kV	34	40	50
15 minute withstand, DC kV	53	78	103
Continuous and load break current, Amps	630	630	630
Momentary current, kA asym	40	40	40
Fault-close current, (3 times) kA asym	32	32	32
One second current, kA sym	25	25	25
Mechanical endurance, operations	2000	2000	2000

*Suffix RP = Rotary Puffer, SF = Rotary Blade. Inverted designs with top entry bushings are available.

** For 40A rotary puffer style switches: tank depth = 25" (635mm), tank height = 27" (686mm). Dimensions are approximate and do not include entrances, gauges, frames or operators.

** For 40kA rotary blade style switches: tank depth = 23" (584mm), tank height = 28" (711mm). Dimensions are approximate and do not include entrances, gauges, frames or operators.

For typical specifications, go to: gwelec.com/specs.html

For contact principle, see page 30 & 31.

Linear Puffer (PI) Ratings		One-line Diagram (Horizontal)	Voltage (kv)	MOM (kA) asym.	Catalog Number	Approximate	
						Width in (mm)*	Wt. w/SF ₆ lbs (kg)
Maximum Design Voltage kV	15.5		15	64	GRAM21-376M-64PI	32.5 (825)	600 (270)
Voltage class, kV	15						
Impulse level (BIL), kV	110		15	64	GRAM33-376M-64PI	62.25 (1580)	1400 (635)
One minute withstand, AC kV	35						
One minute withstand, Production test rating, AC kV	34		15	64	GRAM44-376M-64PI	80.5 (2045)	1800 (815)
15 minute withstand, DC kV	53						
Continuous and load break current, Amps	630		15	64	GRAM55-376M-64PI	98.75 (2510)	2200 (1000)
Momentary current, kA asym	64						
Fault-close current, (3 times) kA asym	64		15	64	GRAM66-376M-64PI	117 (2970)	2600 (1180)
One second current, kA sym	40						
Mechanical endurance, operations	2000						

*Suffix PI = Linear Puffer. Inverted designs with top entry bushings are available.

Tank Depth= 34" (865mm), Tank Height=32" (815mm)

Dimensions are approximate and do not include entrances, gauges, frames or operators.

For typical specifications, go to: gwelec.com/specs.html

GRAM Series

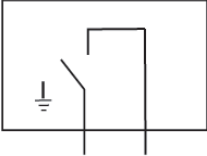
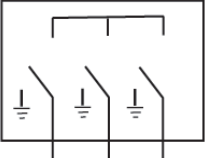
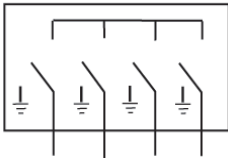
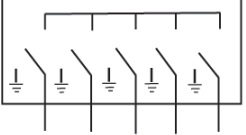
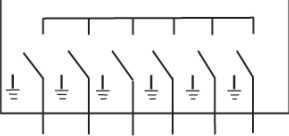
One-line Diagram	Voltage kV	Mom. (kA) asym.	Catalog Number	Width in. (mm)	Weight w/Gas lbs. (kgs)
	15	40	GRAM21-376M-40RP	29 (737)	700 (318)
		40	GRAM21-376M-40SF	37.8 (960)	750 (341)
	25	40	GRAM21-386M-40RP	29 (737)	700 (318)
		40	GRAM21-386M-40SF	37.8 (960)	750 (341)
	35	40	GRAM21-396M-40RP	29 (737)	700 (318)
		15	40	GRAM33-376M-40RP	40.5 (1029)
40			GRAM33-376M-40SF	54 (1372)	1444 (657)
25		40	GRAM33-386M-40RP	40.5 (1029)	950 (431)
		40	GRAM33-386M-40SF	54 (1372)	1444 (657)
35		40	GRAM33-396M-40RP	40.5 (1029)	950 (431)
		15	40	GRAM44-376M-40RP	52 (1321)
	40		GRAM44-376M-40SF	70.3 (1786)	1500 (682)
	25	40	GRAM44-386M-40RP	52 (1321)	1060 (482)
		40	GRAM44-386M-40SF	70.3 (1786)	1500 (682)
	35	40	GRAM44-396M-40RP	52 (1321)	1060 (482)
		15	40	GRAM55-376M-40RP	63.5 (1613)
40			GRAM55-376M-40SF	86.5 (2197)	1713 (779)
25		40	GRAM55-386M-40RP	63.5 (1613)	1500 (681)
		40	GRAM55-386M-40SF	86.5 (2197)	1713 (779)
35		40	GRAM55-396M-40RP	63.5 (1613)	1500 (681)
		15	40	GRAM66-376M-40RP	75 (1905)
	40		GRAM66-376M-40SF	102.8 (2610)	2056 (935)
	25	40	GRAM66-386M-40RP	75 (1905)	1500 (682)
		40	GRAM66-386M-40SF	102.8 (2610)	2010 (914)
	35	40	GRAM66-396M-40RP	75 (1905)	1500 (682)

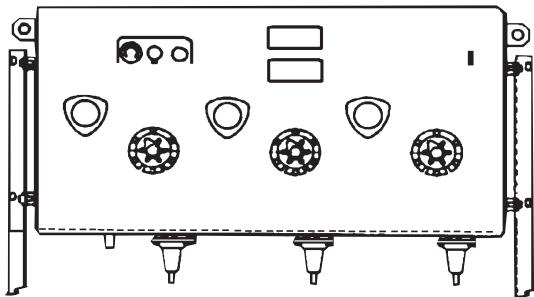

Three Position Load Break Switches

Three Position, Test Ground Switches -TRAM Series (Close-Open-Test Ground)

An integral test position permits safe and easy testing of cable circuits through the switch without having to disconnect elbow or other cable entrance connections. Air bushings are provided and double as a test or grounding point. Handle stops with padlocking provisions help assure proper operation in the desired position.

Rotary Puffer (RP) Ratings			
Maximum Design Voltage kV	15.5	27	38
Voltage class, kV	15	25	35
Impulse level (BIL), kV	110	125	150
One minute withstand, AC kV	35	60	70
One minute withstand, Production test rating, AC kV	34	40	50
15 minute withstand, DC kV	53	78	103
Continuous and load break current, Amps	630	630	630
Momentary current, kA asym	40	40	40
Fault-close current, (3 times) kA asym	32	32	32
One second current, kA sym	25	25	25
Mechanical endurance, operations	2000	2000	2000

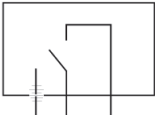
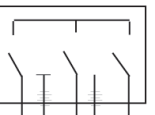
One Line Diagram	Voltage (kV)	MOM (kA) asym.	Catalog Number	Width in (mm)*	Wt. w/Gas, lbs (kg)
	15	40	TRAM21-376M-40RP	34 (864)	700 (318)
		40	TRAM21-376M-40SF	36 (914)	875 (398)
	15	40	TRAM33-376M-40RP	58 (1473)	700 (318)
		40	TRAM33-376M-40SF	62 (1570)	875 (398)

*Suffix RP = Rotary Puffer, SF = Rotary Blade. Inverted designs with top entry bushings are available.

**For 40kA rotary puffer style switches: tank depth = 25" (635mm), tank height = 27" (635mm). Dimensions are approximate and do not include entrances, gauges, frames or operators.

**For 40kA rotary blade style switches: tank depth = 23" (584mm), tank height = 28" (711mm). Dimensions are approximate and do not include entrances, gauges, frames or operators.

For typical specifications, go to: gwelec.com/specs.html
For contact principle, see page 30 and 31.

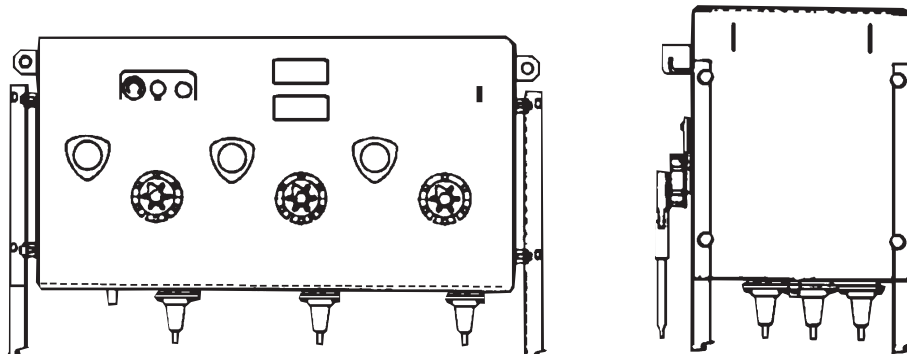

Three Position Load Break Switches

Three Position, Manual Transfer Selector Switches

An integral third close or tie position permits selector switch flexibility for configurations having two or more feeders.

RAD and RAJ Series (Close-Open-Close)

An integral third close position permits selector switching when feeders cannot be paralleled.

RAC and RAL Series (Close-Open-Tie)

An integral third tie position permits selector switching when systems can be paralleled together.

Rotary Puffer (RP) Ratings

Maximum Design Voltage kV	15.5	27	38
Voltage class, kV	15	25	35
Impulse level (BIL), kV	110	125	150
One minute withstand, AC kV	35	60	70
One minute withstand, Production test rating, AC kV	34	40	50
15 minute withstand, DC kV	53	78	103
Continuous and load break current, Amps	630	630	630
Momentary current, kA asym	40	40	40
Fault-close current, (3 times) kA asym	32	32	32
One second current, kA sym	25	25	25
Mechanical endurance, operations	2000	2000	2000

For typical specifications, go to: gwelec.com/specs.html
For contact principle, see pages: 32 and 33.
*Suffix RP = Rotary Puffer, SF = Rotary Blade.

Dimensions are approximate.
Do not use for construction.

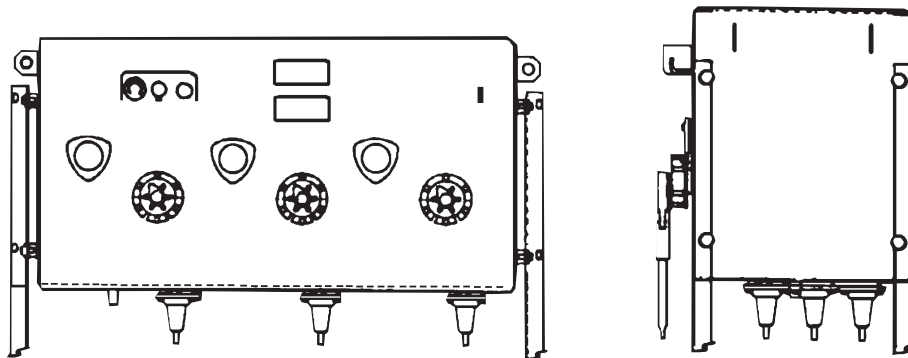

Three Position Load Break Switches

One Line Diagram	Voltage (kV)	MOM (kA) asym.	Catalog Number	Width in (mm)*	Wt. w/Gas lbs (kg)
RAD/RAJ (Manual Transfer Switches)					
	15	40	RAD31-376M-40RP	34 (864)	900 (409)
		40	RAD31-376M-40SF	37.8 (960)	1000 (483)
	15	40	RAJ42-376M-40RP	54 (1372)	1000 (909)
		40	RAJ42-376M-40SF	55.3 (1405)	1100 (499)
RAC/RAL (Manual Transfer Switches)					
	15	40	RAC33-376M-40RP	54 (1372)	950 (432)
		40	RAC33-376M-40SF	54 (1372)	1025 (466)
	15	40	RAC44-376M-40RP	68 (1727)	1300 (590)
		40	RAC44-376M-40SF	70.3 (1786)	1350 (614)
	15	40	RAC55-376M-40RP	82.9(2083)	1550 (705)
		40	RAC55-376M-40SF	86.5 (2197)	1675 (761)
	15	40	RAC66-376M-40RP	96 (2438)	1800 (818)
		40	RAC66-376M-40SF	103 (2610)	2000 (909)
	15	40	RAL32-376M-40RP	40 (1016)	900 (409)
		40	RAL32-376M-40SF	36 (914)	800 (364)

*For 40kA rotary puffer style switches: tank depth = 25" (635mm), tank height = 27" (686mm). Dimensions are approximate and do not include entrances, gauges, frames or operators.

*For 40kA rotary blade style switches: tank depth = 23" (584mm), tank height = 28" (711mm). Dimensions are approximate and do not include entrances, gauges, frames or operators.

Fault Interrupting Switches

Vacuum Interrupters

Vacuum Interrupters combine the total cost and operating benefits of fuseless, electronically controlled, resettable overcurrent protection with the safety and maintenance benefits of a totally sealed, deadfront gas insulated device. The switches are designed for automatic single or three phase fault interruption with manual load break capabilities for systems through 38kV, 630A continuous.

FI Mechanism			
Maximum Design Voltage kV	15.5	27	
Voltage class, kV	15	25	
Impulse level (BIL), kV	110	125	
One minute withstand, AC kV	50	60	
One minute withstand, Production test rating, AC kV	34	40	
15 minute withstand, DC kV	53	78	
Continuous and load break current, Amps	630	630	
Symmetrical interrupting rating, kA	12.5*	12.5	
VI Mechanism			
Maximum Design Voltage kV	15.5	27	38
Voltage class, kV	15	25	35
Impulse level (BIL), kV	95	125	150
One minute withstand, AC kV	50	60	70
One minute withstand, Production test rating, AC kV	34	40	50
15 minute withstand, DC kV	53	78	103
Continuous and load break current, Amps	630	630	630
Symmetrical interrupting rating, kA (20kA available)	12	12	12
NI Mechanism			
Maximum Design Voltage kV	15.5	27	38
Voltage class, kV	15	25	35
Impulse level (BIL), kV	95	125	150
One minute withstand, AC kV	50	60	70
One minute withstand, Production test rating, AC kV	34	40	50
15 minute withstand, DC kV	53	78	103
Continuous and load break current, Amps	630	630	630
Symmetrical interrupting rating, kA (12.5kA or 20kA also available)	25	25	25

*16kA available upon request

For 200A models, replace the "6" with "2", i.e. VI21-172-12-4.

For Model VI (single phase): height = 37" (940mm), depth = 33" (838mm).

For Model VI (three phase-15-27kV): height = 33" (838mm), depth = 15" (381mm).

For Model VI (three phase-38kV): height = 38" (965mm), depth = 15" (381mm).

For Model FI (three phase): At 15-25kV: height = 31" (787mm), depth = 22" (559mm).

For typical specifications, go to: gwelec.com/specs.html

For contact principle, see pages 32 and 33.

Vacuum Interrupter Switches

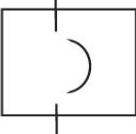
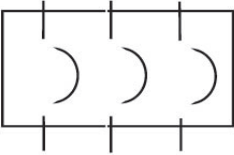
Phase	Three line diagram	Voltage (kV)	Amp	Catalog number	Width in (mm)*	Wt. w/Gas, lbs (kg)
1		15	630	VI20-176-12-4	19 (483)	285 (130)
		25	630	VI20-186-12-4	19 (483)	285 (130)
		35	630	VI20-196-12-4	19 (483)	285 (130)
3		15	630	VPNI20-376-25-4F	45 (1146)	1050 (477)
			630	VPFI20-376-12-4F	38.1 (969)	800 (363)
			630	VPVI20-376-12-4F	50.5 (1283)	1100 (500)
		25	630	VPNI20-386-25-4F	45 (1146)	1050 (477)
			630	VPFI20-386-12-4F	38.1 (969)	800 (363)
			630	VPVI20-386-12-4F	50.5 (1283)	1100 (500)
		35	630	VPNI20-396-12-4F	45 (1146)	1050 (477)
			630	VPVI20-396-12-4F	50.5 (1283)	1100 (500)

For 200A models, replace the "6" with "2", i.e. VI21-172-12-4.

For Model VI (single phase): height = 37" (940mm), depth = 33" (838mm).

For Model VI (three phase-15-27kV): height = 33" (838mm), depth = 15" (381mm).

For Model VI (three phase-38kV): height = 38" (965mm), depth = 15" (381mm).

For Model FI (three phase): At 15-25kV: height = 31" (787mm), depth = 22" (559mm).

For typical specifications, go to gwelec.com/specs.html
For contact principle, see pages 32 and 33.

Dimensions are approximate.
Do not use for construction.

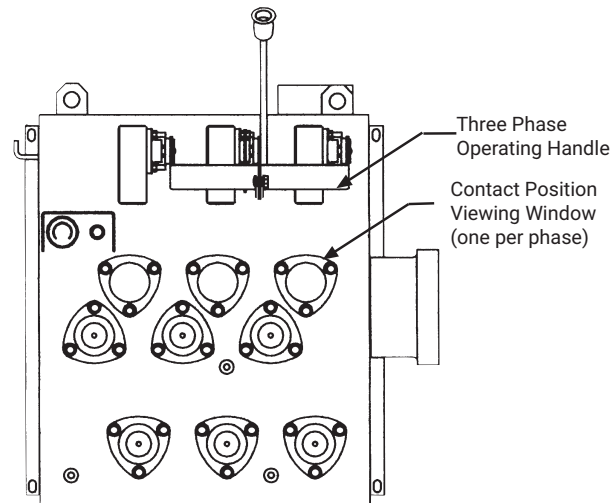
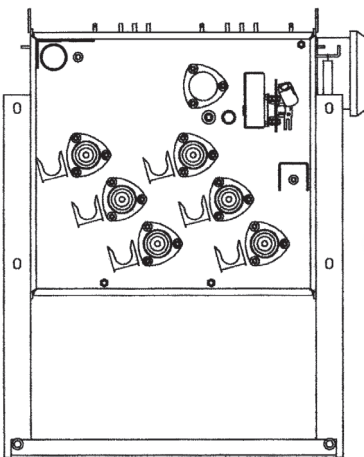

Two Position Fused Switches

For applications requiring current limitation and overcurrent interruption through 50kA symmetrical, air canister style current limiting fusing is available..

Canister Fuses

Integral air insulated, canister style current limiting fusing is available for systems through 23kV. Canister style fused switches feature compact, dead-front construction with mechanical or key interlocking arrangements preventing access to the fuses unless the switch is in the open position. Safe, quick fuse replacement is accomplished using conventional tools and without exposing switch dielectric or current carrying parts to environmental contamination. Two fuses can be connected in parallel to double the capacity rating of the switch. The general purpose fuses are IEEE C37.473.C rated and can interrupt both high and low level fault currents while limiting the available fault current on the system.

Switch Ratings		
Maximum Design Voltage kV	15.5	27
Voltage class, kV	15	25
Impulse level (BIL), kV	110	125
One minute withstand, AC kV	35	60
One minute withstand, Production test rating, AC kV	34	40
15 minute withstand, DC kV	53	78
Continuous and load break current, Amps	200	200
Momentary current, kA asym	25.6	20
Fault-close current, (3 times) kA asym	25.6	20
One second current, kA sym	16	12.5
Operations load interrupting endurance at 600A	500	350
Mechanical endurance, operations	2000	2000



Canister fuses incorporate a provision for hookstick removal and replacement.

Air Canister Fuse Ratings		
Types of Fuse Holders by Voltage Class	Single Holder Fuse Ratings	Parallel Holder Fuse Ratings
8.3kV Max. 95kV BIL	18 to 32 Amp at 4.3kV Max.	90 to 164 Amp at 4.3kV Max.
	6 to 72 Amp at 5.5kV Max.	80 to 144 Amp at 5.5kV Max.
	1.5 to 40 Amp at 8.3kV Max.	50 to 80 Amp at 8.3kV Max.
15.5kV Max. 125kV BIL	1.5 to 40 Amp at 15.5kV Max.	34 to 80 Amp at 15.5kV Max.*
23kV Max. 125kV BIL	6 to 29 Amp at 23kV Max.	30 to 58 kV Amp at 23kV Max.*

Voltage class measured line-to-ground.

*Fuses rated above 25 Amps are required to be non-gassing fuses.

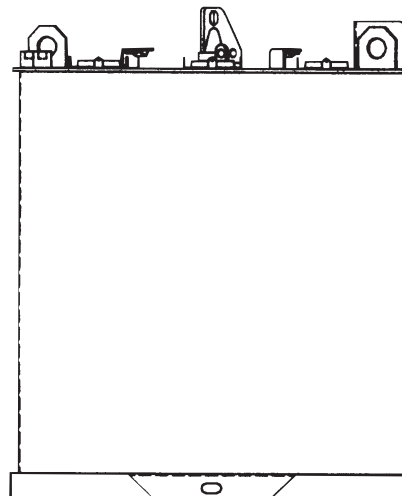
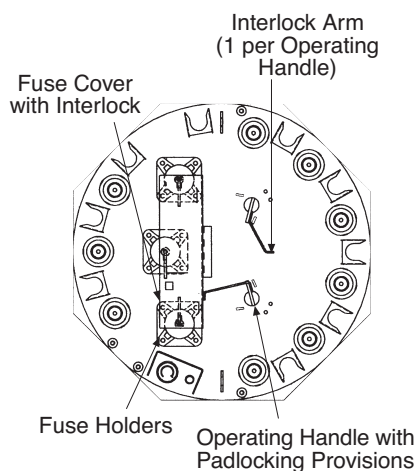

Fault Interrupting Switches

Two Position, Fused Rotary Puffer Style

Circular Tank Design

G&W's circular tank RP switch incorporates all bushings and operating apparatus on the top of the switch for easy access from above ground if required. Switches are rated through 25kV, 200A. Two way and three way configurations are available for either single, two or three phase applications. Two way and three way configurations are available for either single, two or three phase applications. Single and parallel fuse holders are available.

Single Fuse Holders

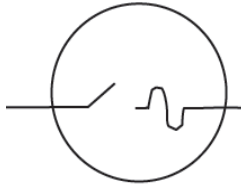
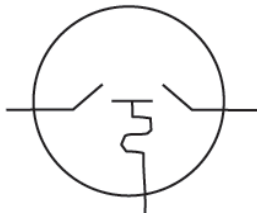
One Line Diagram	Voltage (kV)	Number of \emptyset	Number of Fuses	Catalog Number	Dimensions Inches (mm)		Wt. w/Gas ₆ lbs (kg)
					A	B	
	4,3,5,5, or 8.3	1	1	8FRPR1W	29 (737)	31 (787)	160 (73)
		2	2	8FRPR2W	29 (737)	31 (787)	170 (77)
		3	3	8FRPR3W	29 (737)	31 (787)	190 (86)
	15	1	1	15FRPR1W	29 (737)	31 (787)	160 (73)
		2	2	15FRPR2W	29 (737)	31 (787)	170 (77)
		3	3	15FRPR3W	29 (737)	31 (787)	190 (86)
	23	1	1	23FRPR1W	29 (737)	33 (838)	160 (73)
		2	2	23FRPR2W	29 (737)	33 (838)	170 (77)
		3	3	23FRPR3W	29 (737)	33 (838)	180 (82)
	4,3,5,5, or 8.3	1	1	8FRPRL1W	35 (889)	31 (787)	200 (91)
		2	2	8FRPRL2W	35 (889)	31 (787)	210 (95)
		3	3	8FRPRL3W	35 (889)	31 (787)	220 (100)
	15	1	1	15FRPRL1W	35 (889)	31 (787)	200 (91)
		2	2	15FRPRL2W	35 (889)	31 (787)	210 (95)
		3	3	15FRPRL3W	35 (889)	31 (787)	220 (100)
	23	1	1	23FRPRL1W	35 (889)	33 (838)	200 (91)
		2	2	23FFRPR2W	35 (889)	33 (838)	210 (95)
		3	3	23FFRPR3W	35 (889)	33 (838)	220 (100)

Parallel Fuse Holders

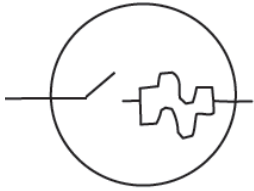
	4,3,5,5, or 8.3	1	2	8FFRPR1W	35 (889)	31 (787)	200 (91)
		2	4	8FFRPR2W	35 (889)	31 (787)	210 (95)
		3	6	8FFRPR3W	35 (889)	31 (787)	220 (100)
	15	1	2	15FFRPR1W	35 (889)	31 (787)	200 (91)
		2	4	15FFRPR2W	35 (889)	31 (787)	210 (95)
		3	6	15FFRPR3W	35 (889)	31 (787)	220 (100)
	23	1	2	23FFRPR1W	35 (889)	33 (838)	200 (91)
		2	4	23FFRPR2W	35 (889)	33 (838)	210 (95)
		3	6	23FFRPR3W	35 (889)	33 (838)	220 (100)

For typical specifications, go to: gwelec.com/specs.html

For contact principle, see page 28.

Dimensions are approximate.

Do not use for construction.



Fault Interrupting Switches

Two Position, Fused Linear Puffer and Rotary Blade Style

Rectangular Tank Design

G&W's rectangular tank linear puffer (PI) and rotary blade (SF) switches are available in two-way through six-way configurations. Bushings and operating apparatus can be front, top, bottom or side mounted. Wall mounting channels and various frame options are available.

FRAM / FGRAM / FRAD Series (Typical Configurations)

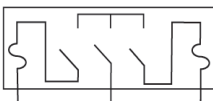
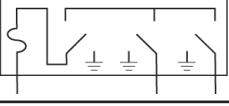
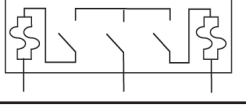
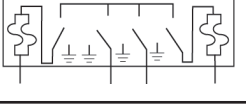
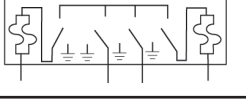
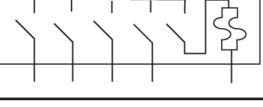
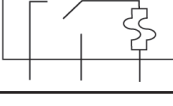
One-line Diagram	Voltage (kV)	Switch Style	Catalog Number	Amp A	Width in. (mm)	Wt. w/Gas lbs. (kg)
	15	PI	FRAM21-376M-40PI	40	26.2 (667)	600 (273)
	15	PI	FRAM33-376M-40PI	40	47.5 (1207)	850 (386)
		PI	FFRAM33-376M-40PI	80	52 (1321)	725 (330)
	15	PI	2FRAM33-376E-40PI	80	61.5 (1562)	970 (440)
	15	SF	FGRAM33-376M-40SF	40	69.5 (1765)	1550 (704)
		SF	FFGRAM33-376M-40SF	80	72.5 (1842)	1600 (727)
	15	PI	2FFRAM33-376M-40PI	80	80.5 (2045)	1750 (795)
	15	PI	2FFRAM44-376M-40PI	80	79.5 (2016)	1700 (773)
	15	SF	2FFGRAM44-376M-40SF	80	105 (2667)	2000 (907)
	15	PI	FFRAM55-376M-40PI	80	67.5 (1715)	1500 (682)
	15	SF	FFRAD31-376-40SF	80	51 (1295)	1000 (454)

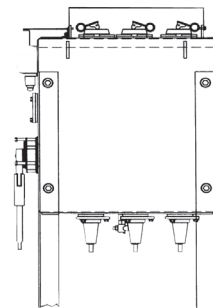
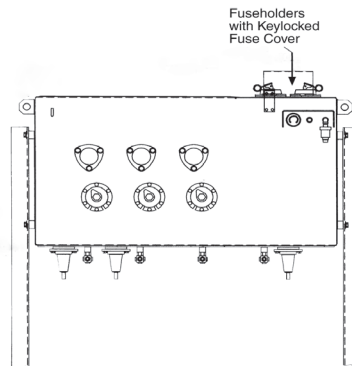
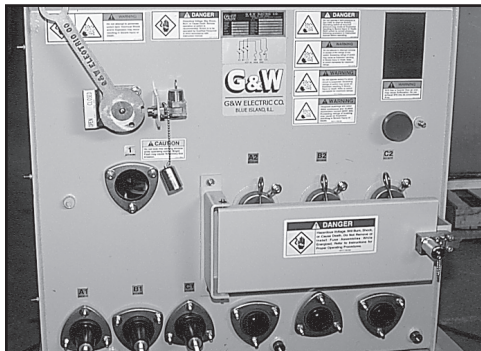

Fault Interrupting Switches

Two Position, Fused Linear Puffer and Rotary Blade Style

FRAM / FGRAM / FRAD Series (Typical Configurations)

For typical specifications, go to:
gwelec.com/specs.html

Ratings for linear puffer (PI) and rotary blade (SF) switches are the same. See contact principle page for SF ratings. For contact principle, see page 29 and 31.

*Catalog number suffix: PI = Linear Puffer, SF = Rotary Blade

For PI switches, optional 6-1/2" phase spacing (SRA style) is available and will increase tank depth by three inches.

**For PI switches: tank depth = 26" (584mm), tank height = 28" (711mm). Dimensions are approximate and do not include entrances, gauges, frames, operators or mounting channels.

**For SF switches: tank depth = 26" (660mm), tank height = 28" (711mm). Dimensions are approximate and do not include entrances, gauges, frames, operators or mounting channels.

Dimensions are approximate.
Do not use for construction.



Switch with front mounted fusing.

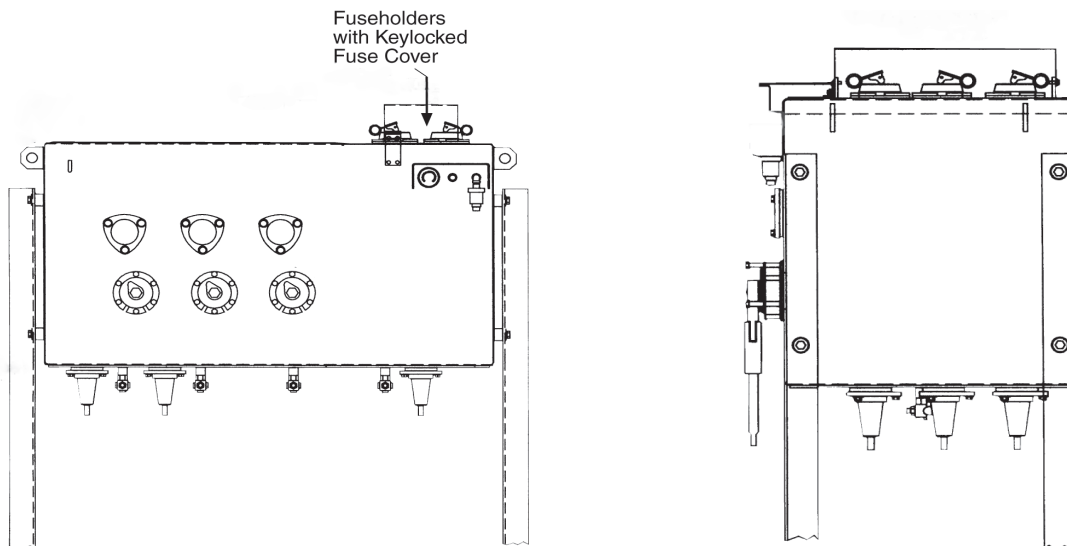

Horizontal style with top mounted fusing.

Contact Principles

Model FI and NI Vacuum Interrupter Mechanism Principle *(Add to appropriate switch specifications)*

Ratings for FI modules available through 15.5kV up to 16kA symmetric interrupting or 25kV with 12.5kA symmetric interrupting symmetric interrupting. Ratings for NI modules available through 35kV, with 12.5kA, 20kA and 25kA symmetric interrupting.

The model FI and NI vacuum

interrupters consist of three vacuum bottles mechanically linked to a single spring-assisted operating mechanism. Once initiated, the interrupting time of the vacuum bottles is approximately 3 cycles (50 millisecond). A position indicator (open-green, closed-red) driven by the operating mechanism and is visible through a viewing window for positive contact position. The mechanical linkage assembly provides a “trip-free” operation permitting the vacuum interrupter to interrupt independent of the operating handle if closing into a faulted circuit.

The control monitors the current on each phase and activates a trip solenoid to open the three vacuum bottles if an overcurrent on any phase is sensed. The control is self-powered by current transformers mounted inside the sealed switch tank. No external power source is required. Load current is required for the control to be activated unless the optional remote power feature is specified. The trip selector is used to select the time-current response curve for the tap circuits. The time-current response curves are chosen with the phase selector switches on the face plate of the control. Selection of time-current characteristics may be made under load or no-load conditions with continuous current ranges in twelve selectable levels. The manual trip and reset of the vacuum interrupter is accomplished through a single handle operating all three phases simultaneously. Motor actuators can be provided. Optional push-button on the controls also permit manual tripping.

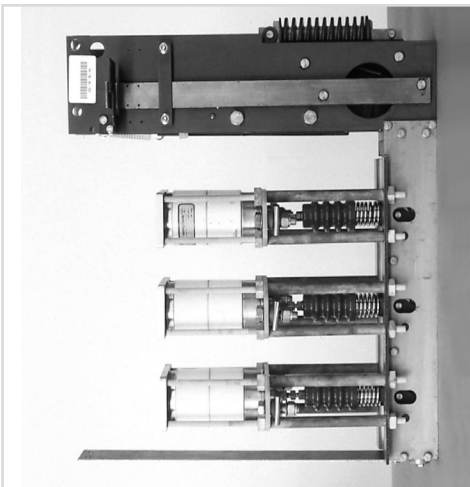

Model FI three phase mechanism.

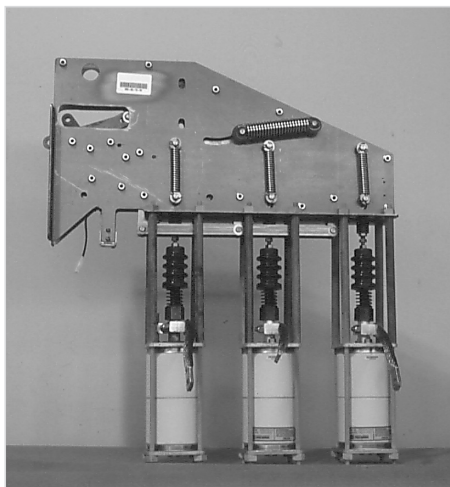

Model NI three phase mechanism.

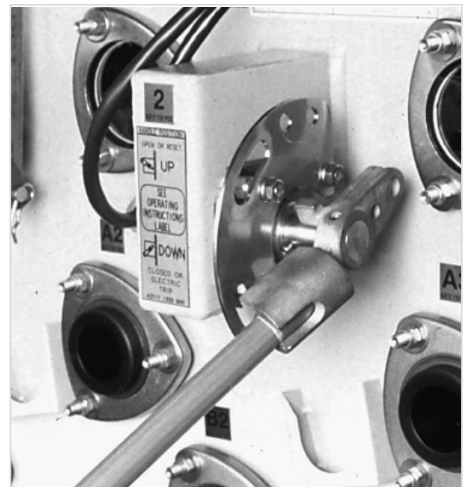

Three phase interrupter operating handle for manual three phase operation and reset.

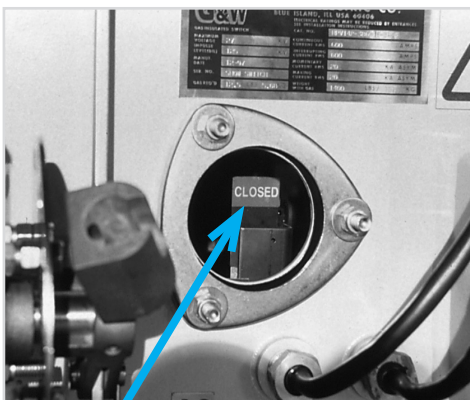

Closed
Position indicators provide visible verification of contact position through viewing windows.

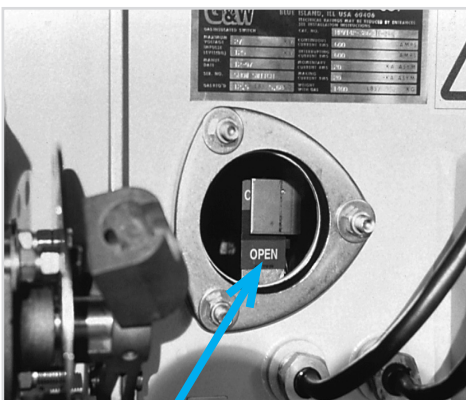

Open



Motor actuators can be added for remote operation.

Contact Principles

Model VI Vacuum Interrupter Mechanism Principle *(Add to appropriate switch specifications)*

Ratings available through 35kV, with 12kA interrupting with an option for 20kA. Mechanisms are field retrofittable between single phase and three phase operation.

For single phase operation, the model VI vacuum interrupter consists of a single vacuum bottle mechanically linked to a spring-assisted operating mechanism. For three phase operation, the single phase mechanisms are mechanically linked together with an external operating handle assembly. These mechanisms are field retrofittable between single phase and three phase operation. In both cases, once initiated, the interrupting time of the vacuum bottles is approximately 3 cycles (50 millisecond). A position indicator (open-green, closed-red) is mounted to the moving contact and is visible through a viewing window for positive contact position. The mechanical linkage assembly provides a "trip-free" operation permitting the vacuum interrupter to interrupt independent of the operating handle if closing into a faulted circuit.

The control monitors the current on each phase and activates a trip solenoid to open one or all three vacuum interrupters if an overcurrent on any phase is sensed. The control is self-powered by current transformers mounted inside the sealed switch tank. No external power source is required. Load current is required for the control to be activated unless the optional remote power feature is specified. The trip selector is used to select the time-current response curve for the tap circuits. Factory setting for single or three phase tripping is standard.

The time-current response curves are chosen with the phase selector switches on the face plate of the control. Selection of time-current characteristics may be made under load or no-load conditions with continuous current ranges in twelve selectable levels. The manual trip and reset of the vacuum interrupter is accomplished through an operating handle. Motor actuators can be provided for remote control. Optional push-button on the control also permits manual tripping.

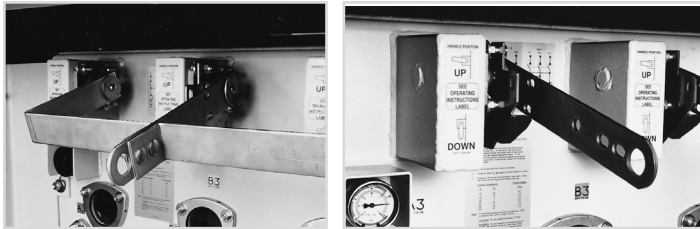

Photos above Interrupter operating handles for manual single phase (right) or three phase (left) operation and reset. Motor actuators can be added to three phase for remote operation.



Position indicators provide contact position indication through viewing windows.

Two Position, Rotary Puffer Style

G&W' Electric's patented Rotary Puffer (RP) style, two-position switches are ideal for manual load break switching, automatic transfer or automated sectionalizing applications rated through 25kV, 630A continuous. This module allows for the smallest switch footprint. Switches are tested to 500 loadbreak operations at 15kV and 350 operations at 25kV. Switches also tested to 2000 mechanical operations. Current limiting fuses or electronically controlled vacuum interrupters can be added for overcurrent protection. G&W Electric's RP style contact system provides extremely efficient, high speed arc extinction for maximum service life.

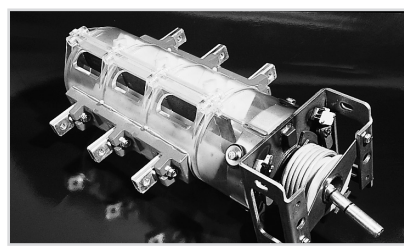
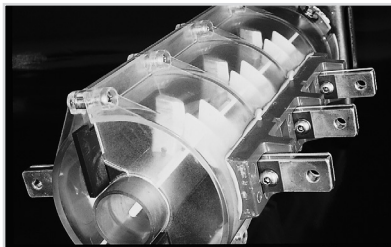

Two position rotary puffer mechanisms

Contact Principles

Two Position, Rotary Puffer Contact Principle

A. The stationary contacts and the multi-chamber rotor (an assembly of interlocking parts which form a rotational framework including moving contacts) are housed in a clear cylindrical shell. The stationary contacts are supported independent of the cable entrance bushings, eliminating possible misalignment resulting from tank deflections. Tank deflections are caused by normal tank pressure variance due to ambient temperature fluctuations. Each rotating contact simultaneously disengages from two stationary contacts, providing two break points per phase. This provides improved interrupting capability as compared to single break contact systems.

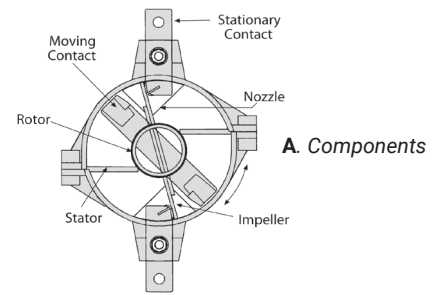

B. As the rotor tube assembly turns to disengage the moving contact from the stationary contacts, dielectric media (gas) is compressed between the impeller and stator. The shell, phase barrier and rotor tube also act to confine the gas for proper compression and flow. The compressed gas is directed through the nozzle into the arc zone. The gas flows (is puffed) across the contacts and around the arc established by the separating contacts, cooling the arc over the length of the nozzle. The cooling action is increased by the higher pressure (due to compression) and the flow of gas which constantly provides a supply of cool gas into the arc zone. At current zero, the temperature of the arc is reduced to the point of deionization. The gas rapidly recovers dielectric strength withstanding the system recovery voltage and preventing re-ignition of current across the contacts.

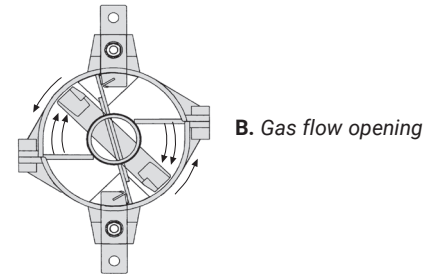

C. As the rotor tube assembly turns to engage the moving contact with the stationary contacts, the impeller induces a flow of gas between the contacts to minimize pre-strike.

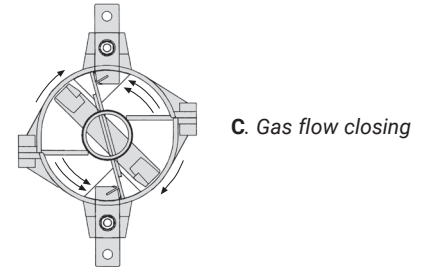

Two or Three Position, Linear Puffer Style

G&W Electric's patented Linear Puffer (LP) style, two or three position switches are ideal for heavy duty manual load break switching, automatic transfer or automated sectionalizing applications rated through 35kV, 900A continuous and 40kA asymmetrical short circuit. Switches are tested to 1200 loadbreak and 2000 mechanical operations. Current limiting fuses or electronically controlled vacuum interrupters can be added for overcurrent protection. G&W Electric's LP style contact system provides extremely efficient, high speed arc extinction for maximum service life.

Two Position Stored Energy Mechanism

Linear puffer switches can be supplied with internal stored energy (cock and trip) mechanisms for both the open and close operators permitting high speed local or remote operation. A separate external trip handle is provided. An optional internal solenoid permits remote operation.



Three phase visible position of contacts.

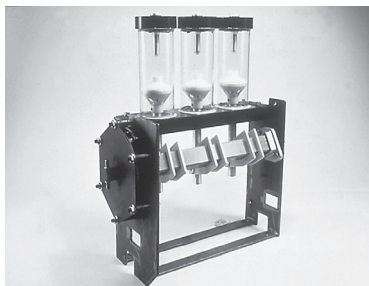

Two position linear puffer mechanism.



Three position linear puffer mechanism

Contact Principles

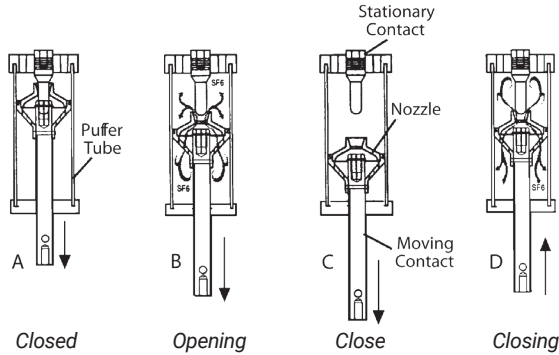

A. The stationary contact and piston assembly (containing the moving contact and nozzle) are housed in clear cylindrical tubes. These are mounted in a modular three-phase assembly which is independent of the switch tank. The stationary contacts are supported independent of the cable entrance bushings, eliminating possible misalignment resulting from tank deflections. Tank deflections are caused by normal tank pressure variance due to ambient temperature fluctuations. This construction eliminates contact alignment difficulties caused by deflections of the switch tank walls. The modular construction also allows testing of the module during assembly and complete flexibility in switch design and configuration. The nozzle which directs the flow of gas has a converging/diverging geometry (see photo) which improves the arc interruption capability over designs using straight throated nozzles. The converging portion of the nozzle has a constantly decreasing flow area up to the nozzle throat minimizing velocity changes in the flow of gas, while improving arc interruption and dielectric recovery.

B. As the contacts separate, the gas is compressed by the piston assembly and directed into the arc zone by the nozzle. The compressed gas flows (is puffed) across the contacts and around the arc established by the separating contacts. The cooling action of the gas is increased by the higher pressure (due to compression) and the flow which constantly provides a supply of cool gas into the arc zone.

C. At current zero the temperature of the arc is reduced to the point of deionization, ceasing the flow of current. The gas rapidly recovers dielectric strength withstanding the system recovery voltage across the contacts.

D. As the contacts are closing, the piston assembly compresses the gas between the contacts. This increases the dielectric strength of the gap, minimizing pre-strike. The contacts are designed using a tulip bayonet construction (see photo). The sliding action of the contacts on engagement provides a self cleaning action of the main current carrying surfaces. The contact fingers are designed for increasing contact pressure with increasing current for proper operation during momentary or close-into-fault conditions. The contacts have arc resistant copper tungsten tips to minimize erosion of material during load switching and prevent damage to the main current transfer area of the contacts.

Three Position, Rotary Puffer Style

For systems through 35kV, 630A

continuous current with 40kA asym. momentary, 32kA asym. close into fault, and 25kA sym. one second current; rotary puffer (RP) style switches are used. G&W Electric's multi-position spring operator permits an integral third switching position to increase the application capability over conventional two position switches. Three position switches combine increased switching flexibility with compact construction.

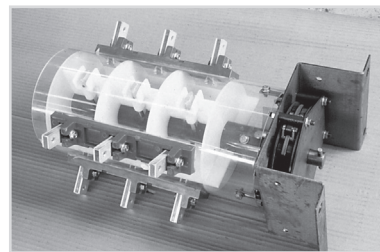

Three position rotary puffer mechanism.

Three Position, Rotary Puffer Contact Principle

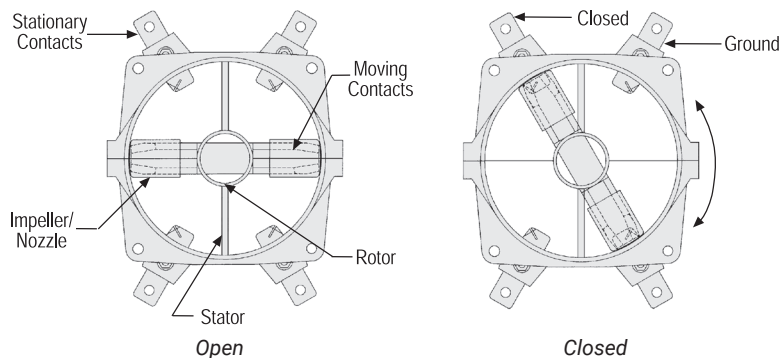

Contact Principles

A. The stationary contacts and the multi-chamber rotor (an assembly of interlocking parts which form a rotational framework including moving contacts) are housed in a clear cylindrical shell. The stationary contacts are supported independent of the cable entrance bushings, eliminating possible misalignment resulting from tank deflections. Tank deflections are caused by normal tank pressure variance due to ambient temperature fluctuations. Each rotating contact simultaneously disengages from two stationary contacts, providing two break points per phase. This provides improved interrupting capability as compared to single break contact systems.

B. As the rotor tube assembly turns to disengage the moving contact from the stationary contacts, dielectric media (gas) is compressed between the impeller and stator. The shell, phase barrier and rotor tube also act to confine the gas for proper compression and flow. The compressed gas is directed through the nozzle into the arc zone. The gas flows (is puffed) across the contacts and around the arc established by the separating contacts, cooling the arc over the length of the nozzle. The cooling action is increased by the higher pressure (due to compression) and the flow of gas which constantly provides a supply of cool gas into the arc zone.

C. At current zero, the temperature of the arc is reduced to the point of deionization. The gas rapidly recovers dielectric strength withstanding the system recovery voltage and preventing re-ignition of current across the contacts.

D. As the rotor tube assembly turns to engage the moving contact with the stationary contacts, the impeller induces a flow of gas between the contacts to minimize pre-strike.

Three Position, Rotary Blade Style

For heavy duty systems through 25kV, 600A continuous and up to 40kA short circuit, rotary blade style switches are used. Switches are tested to 1200 load break and 2000 mechanical operations.

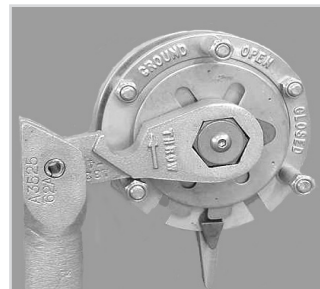

Close up of the switch operator and breakaway handle for a third ground position switch.

Load break switch (SF) ratings		
Maximum Design Voltage kV	15.5	27
Voltage class, kV	15	25
Impulse level (BIL), kV	110	125
One minute withstand, AC kV	35	60
One minute withstand, Production test rating, AC kV	34	40
15 minute withstand, DC kV	53	78
Continuous and load break current, Amps	630	630
Momentary current, kA asym	40	40
Fault-close current, (3 times) kA asym	40	40
One second current, kA sym	25	25
Open gap withstand,kV	200	200
10 operation overload interrupting capability,	3000	3000
Operations load interrupting at 600A	1200	1200
Mechanical endurance, operations	2000	2000

Contact Principles

Three Position, Rotary Blade Contact Principle

G&W Electric's rotary blade contact system permits three position switching capability within a single compact switch. The rotary blade contact system is modular in design and capable of alignment checks and bench testing prior to placement in the switch tank. The switching module is connected to the external operating shaft by means of a sliding coupling. The coupling provides the module with mechanical freedom from the tank walls thereby reducing stress or misalignment due to changing pressure conditions and subsequent deflection of the tank walls.

The switching mechanism is a compression spring operated device which latches in both the open and closed positions to ensure proper contact opening during interruption and closing under normal or fault conditions. The speed of the contacts is independent of the movement of personnel or devices externally operating the switch.

The rotary blade contact system is comprised of plated copper moving contact blades which mate with plated beryllium copper stationary finger contacts. The moving blade is mounted on a molded rocker arm and is connected to either a bus bar or entrance bushing using flexible wire rope. The stationary contacts are supported independent of the cable entrance bushings, eliminating possible misalignment resulting from tank deflections. Tank deflections are caused by normal tank pressure variance due to ambient temperature fluctuations. Reinforced flaps mounted to each moving contact blade forces gas into the arc zone for more efficient interruption. The flexible rope removes the necessity of critical contact alignments.

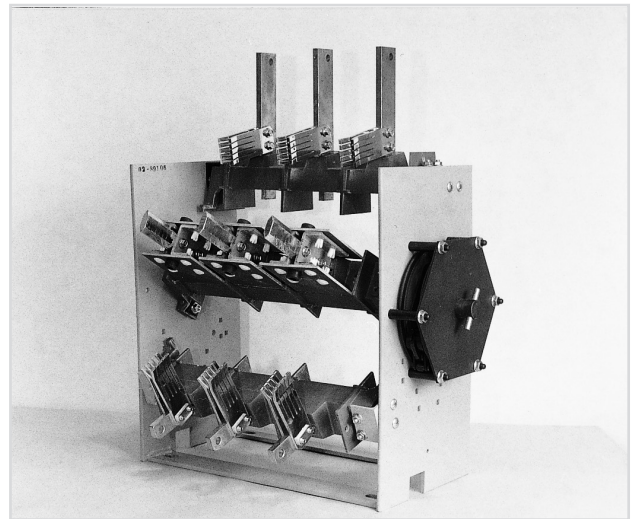
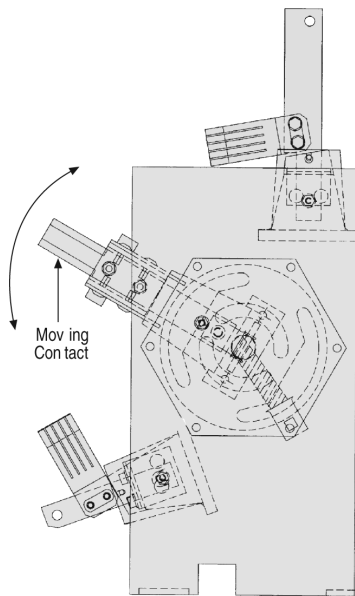

Automation

Switch Remote Control Packages

For electrical remote operation, motor actuators can be added. Various control packages are available:

Single way controls.

- Either stationary or portable
- Powered by 120 or 240VAC or up to 125VDC
- AC powered controls are available with or without battery backup.

Multi-way controls

- Switch controls, such as Schweitzer's SEL 451, are available for applications requiring one control to operate numerous switch ways on one switch or numerous switches from one control.



Vault switch with SEL controls.

LaZer® Power Grid Automation

The G&W Electric LaZer® Automation System is the culmination of decades of experience designing innovative power automation solutions. From simple automatic transfer schemes to the most complex SCADA/master station configurations, our comprehensive solutions are custom engineered to meet your precise application needs.

LaZer Power Grid Automation solutions combine proven power grid hardware and software with decades of system integration experience that can reduce or eliminate outage costs and improve your bottom line.

Lazer is a protection and control package that features one or more protective relays, equipped with distributed capabilities and peer-to-peer communication to make intelligent operating decisions and to monitor field conditions. Lazer focuses on critical load installations to maximize service reliability.

G&W Electric's LaZer Power Grid Automation solutions combine proven power grid hardware and software with decades of system integration experience that can reduce or eliminate outage costs and improve your bottom line. The system specifically addresses fault detection, isolation and restoration (FDIR) requirements. It continuously monitors the circuit. When it senses an electrical overload or short circuit fault within its protection zone, it issues a command to the appropriate switchgear to trip-open within a pre-determined time delay based on the severity of the fault.

Communication with other upstream and downstream Lazer devices function continually to determine what other actions are required to reconfigure the circuits to automatically restore power to customers connected to the unfaulted lines. The entire process from fault detection to system restoration can typically be completed within 60 seconds or less.

Flexible communication and open protocols are critical for integrating to existing Smart Grids and expanding to handle future needs. Lazer solutions offer flexible communication using hardwired connections, fiber optic cable, or a range of wireless technologies on RS232, RS485, and Ethernet ports. Some of the different protocols available are:

- DNP 3.0
- SEL Mirrored Bits® (proprietary)
- IEC61850 with GOOSE messaging

Project Examples

- Distributed automatic transfer including reclosers and SEL-451 controls over fiber optic cable.
- Open Loop FDIR including switches, ABB REC670 relays and ABB RTU560 HMI.
- Closed Loop FDIR including switches, SEL-351s and Survalent software.
- Open Loop Upgrade including switches, SEL-451 and SEL-751A over fiber optic.
- High Speed Single Phase Tripping Closed Loop including reclosers and SEL-651R over fiber optic cable.



FLISR (Fault Locations, Isolation and Service Restoration) shown on a monitoring computer

Automatic Transfer

ATC 451

G&W Electric's ATC 451 automatic transfer controls are available for G&W Electric gas switchgear through 38kV. Switches can be dry or submersible vault, padmount or pole mount styles. The two incoming source ways can be located in one switch, or in two separate switches for added redundancy. Manual switches can be retrofitted in the field. Standard transfer times are within 8-10 seconds.



ATC 451 control panel.

Features:

- Uses SEL 451 relay - ATC 451 control utilizes the field proven Schweitzer SEL 451 relay for its protection logic and programming scheme
- Plug and play construction - The ATC 451 is pre-programmed and packaged with all required components to simplify installation and maximize reliable performance. Various styles of NEMA enclosures are available depending on the application.
- Overcurrent protection for two fault interrupting ways - The ATC 451 can eliminate the need for separate vacuum interrupter controls. Depending on user preference and system protection schemes, various styles of separate interrupter controls are available.
- SCADA ready - Each ATC 451 comes standard with several serial ports for communication to SCADA systems. Multiple protocols are available including DNP3.0 (standard), Mirrored Bits (standard), and IEC 61850 (option). Ethernet or fiber optic ports for communications are also available options.
- Lazer[®] ready - The SCADA ready capability simplifies the requirements for communication to other intelligent field devices for automatic power restoration schemes. This simplifies the integration of the ATC into any G&W pre-engineered Lazer automation system where automatic transfer is required.
- Generator source capability - The 451 can be programmed to permit a standby generator to be used instead of a second utility source.
- Bus tie configurations - The ATC 451 can be used with a bus-tie switch permitting automatic transfer where the load is normally balanced between two sources.
- User friendly controls - Large pushbuttons are clearly labeled and provide easy control commands from the front panel.
- Sequence of event recorder - Each ATC 451 includes a Sequence of Events Recorder which will record the last 1000 entries, including setting changes, powerups, and selectable logic elements.
- Flexible voltage sensing options Integral voltage sensing bushings are available which eliminate the need for cumbersome add-on devices. The bushings are 600A rated, fully submersible, and provide one analog output per phase and one digital output per way for voltage monitoring (when using amplification circuitry). Elbow mounted sensors and potential transformers are also available.

Faster Transfer Speed Options

Switches can be provided with internal cock-and-trip (stored energy) mechanisms permitting transfer times within 15-20 cycles. These switches incorporate an external, hookstick operable handle permitting manual open or close without having to disconnect the motor actuator. Contact G&W if faster transfer times are required.

Accessories and Options

G&W Electric Vacuum Interrupter Controls

The control monitors the current, sends a trip signal which opens the vacuum interrupters and interrupts the fault current. G&W controls are self-powered from the current transformers located inside the solid dielectric module. Controls can be equipped to accept a trip input from a relay or communication device. G&W also offers other controls, such as SEL relays, depending on the application.

The standard control enclosure for padmount applications is fiberglass NEMA 4X (IP56) rated. For vault and subsurface applications, G&W recommends the Type 7 control. The Type 7 is mounted within the switch's mechanism housing and has an IP68 rating for long term submersion.

Control Options

Type 1 controls operate three, single phase vacuum interrupting mechanisms. The Type 1 control can be field set for either single phase or three phase trip mode. It is used on switches with either single phase reset or three phase reset handles. When in the three phase mode, all three phases trip if the selected trip level of any individual phase is reached. Trip level selections can be made under load or no-load conditions with 12 selectable minimum trip settings. Two ranges of minimum trip settings are available, 15 to 300 Amps and 30 to 600 Amps. Each unit is pre-programmed with 30 user selectable Time Current Characteristic (TCC) curves. The curve selection can be set or changed while the switch is energized.

An 8 pole dip switch allows the user to choose the TCC that best matches their individual coordination requirements. A label provides a key for the dip switch settings. As protection or coordination requirements change, settings can easily be changed while the switch is energized. Pressing the manual trip button when the control is powered, electronically trips all three phases of the vacuum interrupter. Each control also includes "Last Cause of Trip" LEDs. These LEDs indicate which phase experienced an overcurrent condition, or that the control was given an external or manual trip command.

Type 2 controls provide a user friendly interface for quick and easy programming. Trip level selections can be made under load or no-load conditions with current ranges in 12 selectable levels. Two ranges of minimum trip settings are available, 15 to 300 amps and 30 to 600 amps. Each unit is pre-programmed with 30 Time Current Characteristic (TCC) curves. The curve selection can be set or changed at any time.

An 8 pole dip switch allows the user to choose the TCC curve which best matches their specific coordination requirements. The control can be factory preset to meet the user's requirements. As protection or coordination requirements change, settings can easily be changed in the field. Pressing the manual trip button when the control is powered up trips all three phases of the vacuum interrupter. Each control also includes "Last Cause of Trip" LEDs. These LEDs indicate what caused the control to issue a trip command - an over current condition, Ground Fault, Instantaneous, or an external or manual trip command.

Type 2 controls offer the following features:

- Three phase protection
- Minimum trip setting for all three phases with one selector switch
- Adjustable phase time delay
- Ground fault (phase imbalance) for protection of large three phase motors or transformers. The ground trip setting is represented as a percent of the minimum trip setting.
- Instantaneous trip and inrush restraint features



Type 1 control



Type 2 control

Type 3 and 4 controls provide advanced protection functions. There are two versions of these controls, each with different protection elements.

The EZset version includes:

- Phase Minimum Trip
- Phase Time Delay
- Phase Instantaneous
- Phase Minimum Responses
- Phase Inrush (Cold Load Pickup) Restraint
- Ground Fault (phase imbalance) Minimum Trip with Separate Curve
- 30 Phase/Ground Fault Curve selectors

The Plus version includes all of the above, and in addition includes

- Ground Fault Time Delay
- Ground Fault Instantaneous
- Ground Fault Minimum Responses
- Ground Fault Inrush (Cold Lead Pickup) Restraints
- 60 Phase/Ground Fault curves including 5 User Creatable Curves
- Maintenance Setting Group

The Type 3 and 4 controls record the 16 most recent Cause of Trip Events. The Type 3 EZset includes a display and keypad for entering programming parameters and viewing the Cause of Trip Events. The Type 3 Plus, and Type 4 EZset and Plus utilize a laptop programming kit to enter the settings. The laptop programming kit can also be used to download and store the settings and Cause of Trip Events.



Type 3 control

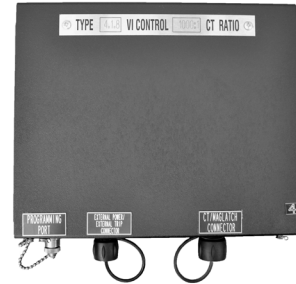

Type 4.1 control in IP68 rated enclosure

3-1/C, 600A / 900A or 200A Voltage Sensing Bushings

G&W's Voltage Sensing Bushing (VSB) system is a temperature compensated, built-in, voltage measuring system that eliminates the need for PTs when analog phase to ground voltage monitoring is required. Compared to potential transformers, the VS bushing system offers these benefits:

- Significant cost savings
- Cleaner, less cumbersome installation
- Less space required
- Fewer add-on components which could potentially fail
- Installed and tested prior to shipment
- Can be field calibrated

The VS bushing system utilizes a capacitively coupled screen which is embedded within the epoxy bushing. The low energy output of the screen can be directly read by some relays. Alternatively, the output is amplified by integral circuitry, resulting in a 0-120 VAC analog output suitable for direct connection to any relay, IED or RTU. The circuitry incorporates built-in calibration and temperature compensation which improve accuracy.

600A / 900A Voltage Sensing Bushings

Bushings are designed to IEEE 386 standards with standard interface accepting conventional elbow style connectors and include an aluminum conductor with 5/8"-11 aluminum threaded stud and aluminum single hole pad (elbows must be ordered separately). Bushings are bolt-on style. Copper studs are available. For bottom entry switches, recommended switch frame height is 42" for all voltages.



200A Voltage Sensing Bushings

Bushings are designed to IEEE 386 standards with standard interface accepting deadbreak or loadbreak inserts and conventional elbow connectors (inserts and elbows must be ordered separately). A copper conductor is standard. For bottom entry switches, recommended switch frame height is 42" for all voltages.



General Ratings

Use on: Grounded wye systems

- Operating temperature: -40°C to +65°C
- Storage temperature: -50°C to +65°C

Input Ratings

Input voltage range (phase to ground) options:

- Low Energy: 1.2 - 4.61 or 4.62 - 21.9kV
- Amplified: 1.7 - 6.2 or 6.2 - 21.9
- Frequency range: 48Hz - 61.2Hz

Output Ratings

Low Energy output voltage:

- 8 VAC

Low Energy Relay Input Impedance:

- 1M Ω

Nominal amplified output voltage:

- 120 VAC with digital output contact (1 per 3 phase set)

Digital pick-up voltage:

- 90% of Vnom (on all phases)

Digital drop-off voltage:

- 75% of Vnom (on any phase)

Maximum burden (per output):

- 0.06VA

Low Energy accuracy:

- +/- 4% from -40°C to 65°C
- (+/- 2% from -20°C to 65°C)

Amplified accuracy:

- +/- 5% from -40°C to 65°C

3-1/C, 600A Quik-Change Apparatus Bushings

Cable entrance bushings can be damaged at any time due to improper handling, accidental shifting during shipment, elbow failure or even normal wear and tear. In the case of gas insulated switches where the tank is totally welded, conventional bushing replacement means sending the switch back to the factory for repair. G&W Electric's exclusive Quik-Change Disconnectable Bushing permits quick, easy field replacement without having to open the switch tank.

Bushings are designed to IEEE 386 standards with standard interface accepting conventional elbow style connectors and include an aluminum conductor with 5/8"-11 aluminum threaded stud and aluminum single hole pad (elbows must be ordered separately). Copper studs are available. For bottom entry switches, recommended switch frame height is 42" for all voltages.

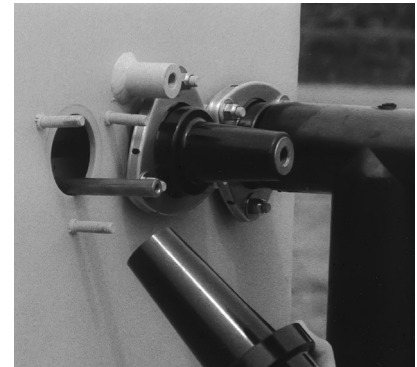

3-1/C, 600A / 900A Apparatus Bushings

Bushings are designed to IEEE 386 standards with standard interface accepting conventional elbow style connectors and include an aluminum conductor with 5/8"-11 aluminum threaded stud and aluminum single hole pad for a 600A rating (elbows must be ordered separately). A copper conductor is available which extends the continuous current rating to 900A. For bottom entry switches, recommended switch frame height is 42" for all voltages. Welded flange bushings are available.

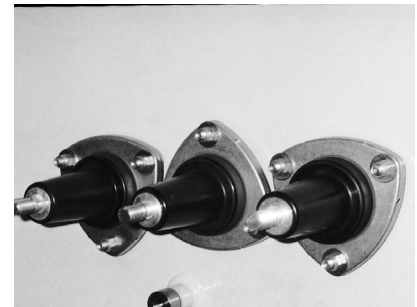

3-1/C, 200A Deepwell Bushings

Bushings are designed to IEEE 386 standards with standard interface accepting deadbreak or loadbreak inserts and conventional elbow connectors (inserts and elbows must be ordered separately). A copper conductor is standard. For bottom entry switches, recommended switch frame height is 42" for all voltages. Welded flange bushings are available.



3-1/C, 600A Apparatus Bushings - Welded Flange style

Bushings are designed to IEEE 386 standards with standard interface accepting conventional elbow style connectors. Bushings include a stainless steel flange and an aluminum conductor with 5/8"-11 aluminum threaded stud. Elbows must be ordered separately. 200A deepwell welded flange bushings are also available.

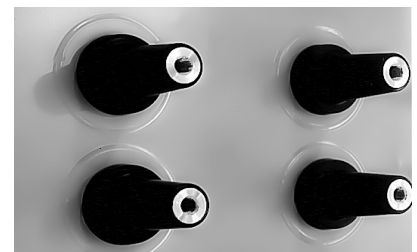

Accessories and Options

3-1/C, 600A Open Stud Bushings

Open stud bushings are furnished standard with 3/4"-16 threaded copper stud connectors and require G&W air termination kits (G&W air termination kits must be ordered separately. See below). For bottom entry switches, recommended switch frame height is 42" for all voltages where this bushing is used. If other than G&W termination kits are used, a NEMA 2-hole pad must be specified.

NOTE: 1. Bushings are also available with NEMA 2-hole pad. G&W Electric air termination kits must be purchased separately.

kV	Amp	kV BIL	Wt.30 set lbs. (kgs)
15	600	110	35 (16)

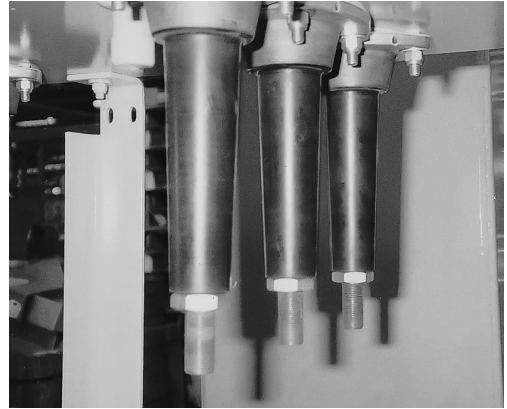

Air Tape Termination Kits

Tape termination kits include all material required for fully shielded air terminations. Specify by completing the catalog number below:

AT XXXX MR - YY - ZZ

XXXX = Conductor size, i.e. #4AWG (0004), 4/0 (04/0), 1000kcm (1000), etc.
 YY = Conductor type, i.e. Stranded Compressed (SC), Compact Round (CR).
 ZZ = Connector style, i.e. Aluminum Crimp (AC), Copper Solder (CS), Copper Crimp (CC).

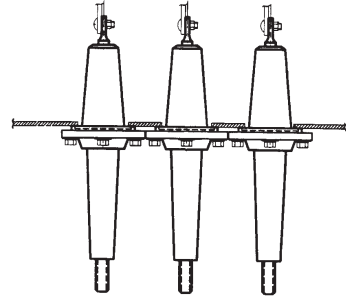

3/C, 600A Stud Bushing Compartment

Stud bushing compartments include stud bushings with copper conductor, cast iron or non-magnetic cast aluminum mounting plate, shape C body and compartment, solder connector for copper conductors (aluminum conductors require compression style connectors), and WS, RS or DP entrances. Entrance style is dependent upon cable construction. Specify complete cable data when ordering. Accessory entrance fittings may also be required. Stud bushing compartments are designed for a maximum conductor size of 750KCM aluminum or 1000KCM copper. For bottom entry switches, recommended switch frame height is 60" for all voltages. **Stress cone kits and compound are required. Consult factory for proper compound selection.**

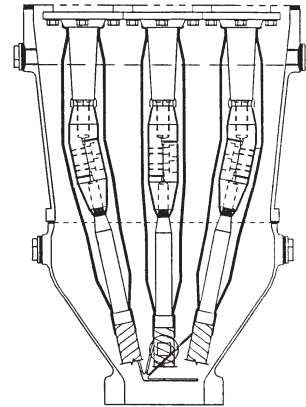

kV	Amp	Wt.30 set lbs. (kgs)	Comp'd Req'd gals (L)
15	600	140 (64)	35 (16)

Stress Cone Kits

Stress cone kits include all material required for fully shielded air terminations. Specify solder (copper) or compression (copper or aluminum) connector and complete cable data. Kits may differ depending upon cable insulation type.

Conductor Size AWG/KCM (mm ²)	Catalog Number
4-4/0 (21-107)	T1MR
250-500 (127-253)	T2MR
600-1000 (304-507)	T3MR

Accessories and Options

Gas Pressure Gauge and Fill Valve (Standard)

The pressure gauge is a "GO-NO-GO" style which is color coded to simplify verification of proper operating conditions. A Schraeder type fill valve permits refilling in the field. The gauge and fill valve are made of brass for corrosion resistance. Both components are protected by a steel guard.



Low Pressure Warning Devices

Are factory set at 5 psig and permit remote indication of internal tank pressure. It can also be used for low pressure control lockout. One Form C contact is provided for wiring by the customer. **Recommended for installations where ambient temperature does not fall below 0°F (-15°C).**



Temperature Compensated Gas Density Gauge (Optional)

measures internal tank gas density for maximum precision of switch operating conditions. The gauge is colored coded to simplify reading by operating personnel.



Accessories and Options

Gas Density Switches

permit remote indication of internal tank gas density to assure proper pressure/temperature operating conditions. One Form C contact is provided for wiring by the customer. **Recommended for installations where ambient temperatures fall below 0°F (-15°C).**



VI control window cover (Optional)

The standard control enclosure for padmount applications is fiberglass NEMA 4X (IP56) rated. The control is also available with an option for a fiberglass NEMA 4X (IP56) enclosure with a viewing window.



Key Interlocks (Optional)

may be used as an added safety measure to prevent operation by unauthorized personnel or to assure safe coordination of energized equipment. Switches can be provided with provisions only (two maximum per operating mechanism) or with key interlocks factory installed. Specify locking scheme when ordering, i.e. lock in open, lock in closed or lock in both open and closed position. For key interlocks to be coordinated with other equipment, manufacturer's information must be provided.



Accessories and Options

Options

Select from the following options and add to the appropriate switch specification:

- Stainless steel tank, type 304
- Stainless steel enclosure, type 304 or 316
- Temperature compensating pressure gauge
- Low pressure warning device
- Gas density switch
- 4/0 brass ground lug
- Key interlock provisions
- Key interlocks to lock in open position
- Current transformers for load break ways
- Potential transformers for voltage monitoring and/or control power
- Automatic transfer control type ATC451
- Motor actuators for remote switch operation
- Auxiliary switches for remote switch position indication
- Stationary switch controls for remote switch operation and SCADA integration
- Portable switch controls for remote switch operation
- Remote terminal units and communication packages for SCADA integration
- Operation counters
- Voltage sensors with 120 VAC output or a contact to indicate presence of voltage
- 200A deepwell bushings
- 600A / 900A apparatus bushings
- 200A voltage sensing bushings
- 600A / 900A voltage sensing bushings
- 600A Quik-Change apparatus bushings
- 600A Universal bushings (through 25kV)
- Type 2 vacuum interrupter control including ground fault trip and time delay selector switches (three phase only)
- Type 3 vacuum interrupter control including ground fault trip, inrush restraint, programmable vacuum fluorescent display (VFD)
- Type 4 vacuum interrupter control (same as Type 3 with laptop programming only)
- Clear window cover for Type 1, Type 2, or Type 3 interrupter controls
- Submersible NEMA 6P enclosure or IP68 potted Type 4 for vacuum interrupter control
- SEL relays including 451 and 751A
- ABB relays including REF615, REF620, and REC670
- GE relays including 350, F35, and F60
- External power / trip for vacuum interrupter control
- Refill kit consisting of regulator, hose and gas bottle



DISTRIBUIDOR AUTORIZADO:

Teléfono: +52 (81)8365-0229

ventas@altatecnologia.com.mx

altatecnologia.com.mx

Contact us today

+1.708.388.5010 or info@gwelec.com



Since 1905, G&W Electric has been a leading provider of innovative power grid solutions, including the latest in load and fault interrupting switches, reclosers, system protection equipment, power grid automation and transmission and distribution cable terminations, joints and other cable accessories. G&W is headquartered in Bolingbrook, Illinois, U.S.A., with manufacturing facilities and sales support in more than 100 countries, including Canada, Italy, China, Mexico, Brazil, India, UAE and Singapore. We help our customers meet their challenges and gain a competitive edge through a suite of advanced products and technical services.