

Padmount Style Gas Insulated Switching Solutions



After a century of engineering exceptionally long lasting medium-voltage distribution products, G&W Electric knows power. And more importantly, we know the power of listening. By taking time to understand your application and asking the right questions, we develop a solution that precisely matches your needs. The answer may be our time-tested switches that keep power running seamlessly in mission-critical industries, or an advanced automation system for next-generation smart grids. Whatever your challenge, you'll experience decades of high-performance engineering to meet your needs.

Gas Insulated Solution

We are dedicated to delivering proven solutions that meet and exceed your needs. That's why our engineers ask you questions and listen to find the right solution.

Our gas insulated padmount switches provide load and fault interrupting switching for systems rated through 38kV, 900A continuous, to 25kA symmetrical interrupting. They offer:

- Smart Grid/Lazer® Solutions
- Submersible designs
- Dead-front designs
- Compact construction
- Maintenance-free operation
- Two and three position switching
- Mounting flexibility
- Ease of Automation



General Features

Maximum Operator Safety

Dead front switch construction eliminates any exposed live parts. Spring-assisted mechanisms assure quick make, quick-break operation. Viewing windows permit visual verification of open or closed contacts. Tamper resistant enclosures utilize pentahead bolts and padlocking provisions. Motor actuators are available permitting remote operation. The result is maximum operator safety.

Minimal Maintenance

G&W Electric's gas insulated switches are corrosion-resistant, totally sealed and factory filled. No more field adjustments of critical contact areas or concerns with environmental contamination or intrusions. A periodic check of the pressure gauge is all that is required.



Application Versatility

Multi-way Configurations — Switches are available for either two-position or three-position (incorporating an integral ground, tie or test position) switching. Single or multiple sources can feed multiple loads. Bus tie configurations are available permitting multiple sources to feed different loads within the same switch.

Mounting Flexibility — Horizontal and vertical configurations are available with operating apparatus accessible from the front, top or side compartments. Enclosures are removable for easy cable installation or field replacement.

Bushing Variety — Many bushing styles are available including an exclusive disconnectable style permitting field changeout. Cable entry can be bottom, front, back or side.

Visible Break — Load break switches can incorporate a visible break of all three phases.

Overcurrent Protection — Fusing or electronically controlled, resettable vacuum interrupters are available.

Smart Grid / Lazer Solutions — Complete distribution automation and Smart Grid solutions are available including automatic transfer. G&W Electric's Lazer distribution automation systems provide pre-engineered, time-proven solutions for automatic power restoration.



Load and Fault Interrupting Switches

G&W Electric load and fault interrupting combination switches combine the total cost and operating benefits of fuseless, electronically controlled, resettable overcurrent protection with the safety and maintenance benefits of a totally sealed, dead-front, gas insulated device. The switches are designed for automatic single or three phase fault interruption with manual load break capabilities for systems through 35kV, 630A continuous. Ratings to 900A continuous are available on certain models. Single side access designs are available for confined space applications.

Features include:

Operator Safety offers:

- Switches are totally sealed, dead front and insulated with non-flammable, nontoxic gas.
- Operators are spring assisted for positive quick-make, quick-break operation
- Trip-free mechanism permits interruption independent of the operating handle if closing into a fault
- Viewing windows permit visible indication of interrupter contact position.

Minimal Maintenance

- No routine inspections or dielectric testing
- No contact contamination, rodent problems or insulator maintenance
- A periodic check of the gas pressure gauge is all that is required.

Three Phase Tripping

- Simultaneous three phase tripping is available through the electronics and with three phase operating handles for manual operation and reset

Protection Curve Compatibility offers:

- Solid state electronic controls permit extremely accurate, consistent protection curve characteristics
- Controls can emulate the most common time current curves (TCC) for power fuses, relays and fuse links
- Optional electronic packages can provide ground trip, inrush restraint and adjustable time delay capability

Fully Tested

- Switches are designed and tested per applicable sections of IEEE C37.71, C37.60, C37.74 and IEC 265 standards

Applications

G&W Electric combination switches provide a direct replacement for power fused air and vacuum-in-oil switchgear. Some ideal applications include:

- Transformer and Motor Protection
- Loop and Tap Switching
- Automatic Transfer for Critical Load Applications
- Smart Grid / Lazer Solutions
- Metal clad Switchgear Replacement

Load and Fault Interrupting Switches

Two Position, Front Access Puffer Vacuum Interrupters

Rotary Puffer (RPF)I

Diagonal bushing configurations. Provides smallest footprint with three phase fault interrupting.

Load break switch (RP) ratings		
Maximum Design Voltage kV	15.5	27
Voltage class, kV	15	25
Impulse level (BIL), kV	110	125
One minute withstand, AC kV	35	60
One minute withstand, Production test rating, AC kV	34	40
15 minute withstand, DC kV	53	78
Continuous and load break current, Amps	630	630
Momentary current, kA asym	20	12.5
Fault-close current, (3 times) kA asym	20	12.5
One second current, kA sym*	12.5	12.5
Operations load interrupting endurance at 600A	500	350
Mechanical endurance, operations	2000	2000
Fault interrupter (FI) ratings		
Maximum Design Voltage kV	15.5	27
Voltage class, kV	15	25
Impulse level (BIL), kV	110	125
One minute withstand, AC kV	50	60
One minute withstand, Production test rating, AC kV	34	40
15 minute withstand, DC kV	53	78
Continuous and load break current, Amps	630	630
Symmetrical interrupting rating, kA*	12.5	12.5

*15.5kV available at 16kA sym., 25.6kA asym. current

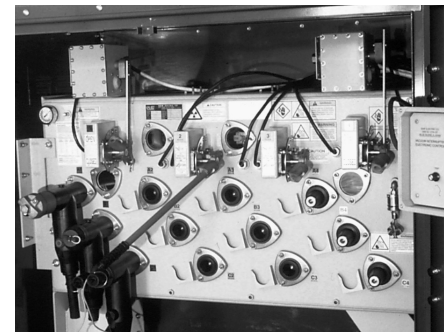

Automated RPF-9F.



Load break operating handle

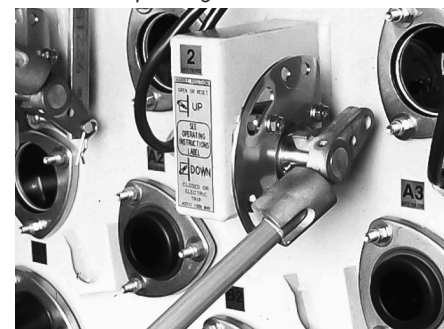

Fault interrupter operating handle.

IEEE C37.60 Fault Interrupting Duty for 12.5kA current rated

Total number of fault interruptions: 116		
Percent of Maximum Interrupting Rating	Approx. Interrupting Current, Amps	No. of Fault Interruptions
15-20%	2,000	44
45-55%	6,000	56
90-100%	12,500	16

Load and Fault Interrupting Switches

Two Position, Front Access, Puffer Vacuum Interrupters con't

Linear Puffer (LPFI)

Provides load break switch with visible break and three phase fault interrupting.

Load break switch (LP) ratings		
Maximum Design Voltage kV	15.5	27
Voltage class, kV	15	25
Impulse level (BIL), kV	110	125
One minute withstand, AC kV	35	60
One minute withstand, Production test rating, AC kV	34	40
15 minute withstand, DC kV	53	78
Continuous and load break current, Amps	630	630
Momentary current, kA asym	40	40
Fault-close current, (3 times) kA asym	40	40
One second current, kA sym	25	25
Open gap withstand, kV	200	200
10 operation overload interrupting capability, Amps	3000	3000
Operations load interrupting endurance at 600A	1200	1200
Mechanical endurance, operations	2000	2000

Fault interrupter (FI) ratings		
Voltage class, kV	15	25
Impulse level (BIL), kV	110	125
One minute withstand, AC kV	50	60
One minute withstand, Production test rating, AC kV	34	40
15 minute withstand, DC kV	53	78
Continuous and load break current, Amps	630	630
Symmetrical interrupting rating, kA*	12.5	12.5

*15.5kV available at 16kA sym., 25.6kA asym. current



Automated LPFI-9F

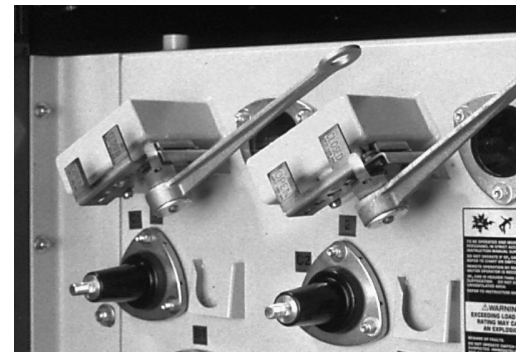

Hookstick operable load break handle



Load break switch visible break

IEEE C37.60 Fault Interrupting Duty for 12.5kA current rated

Total number of fault interruptions: 116		
Percent of Maximum Interrupting Rating	Approx. Interrupting Current, Amps	No. of Fault Interruptions
15-20%	2,000	44
45-55%	6,000	56
90-100%	12,500	16

Two Position, Front Access, Puffer Vacuum Interrupters

Linear Puffer (PNI)

Provides load break switch visible break with 25kA symmetrical three phase fault interrupting.

Load break switch (LP) ratings			
Maximum Design Voltage kV	15.5	27	38
Voltage class, kV	15	25	35
Impulse level (BIL), kV	110	125	150
One minute withstand, AC kV	35	60	70
One minute withstand, Production test rating, AC kV	34	40	50
15 minute withstand, DC kV	53	78	103
Continuous and load break current, Amps*	630	630	630
Momentary current, kA asym	40	40	40
Fault-close current, (3 times) kA asym	40	40	40
One second current, kA sym	25	25	25
Open gap withstand, kV	200	200	200
10 operation overload interrupting capability, Amps	3000	3000	3000
Operations load interrupting at 600A	1200	1200	1200
Mechanical endurance, operations	2000	2000	2000



Front access PNI with load break rotary operator and interrupter single operating handle.

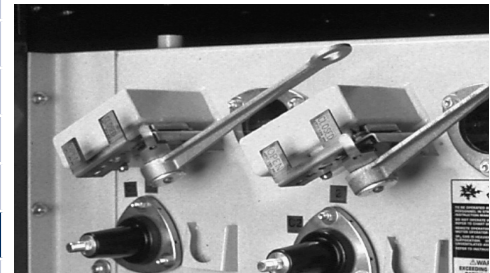

Hookstick operable load break handle.

Fault interrupter (NI) ratings			
Maximum Design Voltage kV	15.5	27	38
Voltage class, kV	15	25	35
Impulse level (BIL), kV	110	125	150
One minute withstand, AC kV	50	60	70
One minute withstand, Production test rating, AC kV	34	40	50
15 minute withstand, DC kV	53	78	103
Continuous and load break current, Amps	630	630	630
Symmetrical interrupting rating, kA**	12.5	12.5	12.5



Interrupter with dual operating handle.

*900A continuous available

**20 or 25kA available

IEEE C37.60 Fault Interrupting Duty for 25kA current rated

Total number of fault interruptions: 116

Percent of Maximum Interrupting Rating	Approx. Interrupting Current, Amps	No. of Fault Interruptions
15-20%	5,000	44
45-55%	12,500	56
90-100%	25,000	16

Two Position, Front Access, Puffer Vacuum Interrupters

Linear Puffer (PVI)

Provides load break switch with visible break and single phase or three phase fault interrupting. Fault interrupters can be changed from single phase to three phase operation in the field.

Load break switch (LP) ratings			
Maximum Design Voltage kV	15.5	27	38
Voltage class, kV	15	25	35
Impulse level (BIL), kV	110	125	150
One minute withstand, AC kV	35	60	70
One minute withstand, Production test rating, AC kV	34	40	50
15 minute withstand, DC kV	53	78	103
Continuous and load break current, Amps* (*900A continuous available.)	630	630	630
Momentary current, kA asym	40	40	40
Fault-close current, (3 times) kA asym	40	40	40
One second current, kA sym	25	25	25
Open gap withstand, kV	200	200	200
10 operation overload interrupting capability, Amps	3000	3000	3000
Operations load interrupting endurance (15kV) at 600A	1200	1200	1200
Mechanical endurance, operations	2000	2000	2000

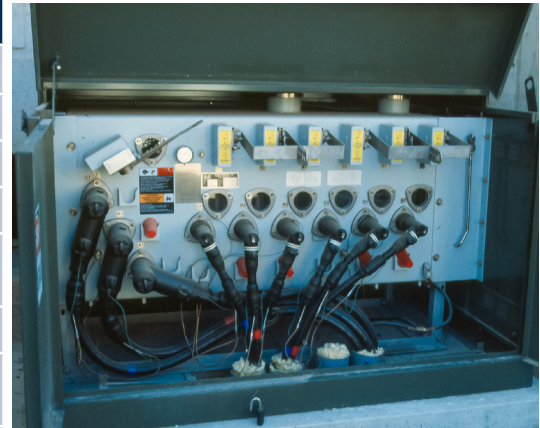

Model PVI-7F with three phase operating handle.



Single phase interrupter operating handles.

Fault interrupter (VI) ratings			
Maximum Design Voltage kV	15.5	27	38
Voltage class, kV	15	25	35
Impulse level (BIL), kV	95	125	150
One minute withstand, AC kV	50	60	70
One minute withstand, Production test rating, AC kV	34	40	50
15 minute withstand, DC kV	53	78	103
Continuous and load break current, Amps	630	630	630
Symmetrical interrupting rating, kA** (**20kA available)	12	12	12



Load break switch visible break.

IEEE C37.60 Fault Interrupting Duty for 12kA current rated

Total number of fault interruptions: 116		
Percent of Maximum Interrupting Rating	Approx. Interrupting Current, Amps	No. of Fault Interruptions
15-20%	2,000	44
45-55%	6,000	56
90-100%	12,000	16

Switch Styles	Height	Depth
RPIF styles	59" (1499mm),	49" (1245mm)
LPFI styles	61" (1549mm)	54" (1372mm)

Switch Styles	Height	Depth
PNI styles	65" (1651mm)	55" (1397mm)
PVI styles	57" (1448mm)	54.5" (1384mm)

Two Position, Front Access, Puffer Vacuum Interrupters

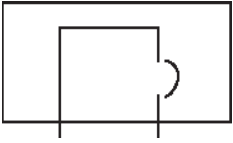
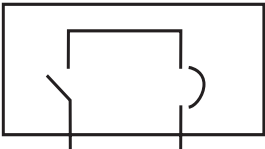
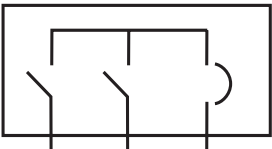
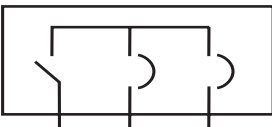
Model	One-line Diagram	Voltage kV	Catalog Number	Width in. (mm)	Weight w/Gas lbs. (kgs)		
4F		15	PNI20-376-25-4F	47.5 (1207)	1500 (682)		
			PFI20-376-12-4F	38.2 (969)	1200 (545)		
			PVI20-376-12-4F	54.8 (1392)	1600 (727)		
		25	PNI20-386-25-4F	47.5 (1207)	1500 (682)		
			PFI20-386-12-4F	38.2 (969)	1200 (545)		
			PVI20-386-12-4F	54.8 (1392)	1600 (727)		
		35	PNI20-396-12-4F	47.5 (1207)	1500 (682)		
			PVI20-396-12-4F	54.8 (1392)	1600 (727)		
		5F		15	RPFI21-376-12-5F	38.2 (969)	1200 (545)
LPFI21-376-12-5F	43.5 (1111)				1475 (670)		
PNI21-376-25-5F	47.5 (1207)				1550 (705)		
PVI21-376-12-5F	54.8 (1392)				1600 (727)		
25	RPFI21-386-12-5F			38.2 (969)	1200 (545)		
	LPFI21-386-12-5F			43.5 (1111)	1475 (670)		
	PNI21-386-25-5F			47.5 (1207)	1550 (705)		
	PVI21-386-12-5F			54.8 (1392)	1600 (727)		
35	PNI21-396-12-5F			47.5 (1207)	1550 (705)		
	PVI21-396-12-5F			61.0 (1549)	1750 (795)		
6F				15	RPFI32-376-12-6F	50.1 (1274)	1500 (681)
					LPFI32-376-12-6F	56.3 (1429)	1775 (807)
		PNI32-376-25-6F	62.5 (1588)		1920 (873)		
		PVI32-376-12-6F	67.3 (1709)		1900 (864)		
		25	RPFI32-386-12-6F	50.1 (1274)	1500 (681)		
			LPFI32-386-12-6F	56.3 (1429)	1775 (807)		
			PNI32-386-25-6F	62.5 (1588)	1920 (873)		
			PVI32-386-12-6F	67.3(1709)	1900 (864)		
		35	PNI32-396-12-6F	62.5 (1588)	1920 (873)		
			PVI32-396-12-6F	73.5 (1867)	2050 (932)		
		7F		15	RPFI31-376-12-7F	50.1 (1274)	1600 (726)
					LPFI31-376-12-7F	55.7 (1415)	2100 (955)
PNI31-376-25-7F	62.5 (1588)				2050 (932)		
PVI31-376-12-7F	75.8 (1925)				2100 (955)		
25	RPFI31-386-12-7F			50.1 (1274)	1600 (726)		
	LPFI31-386-12-7F			55.7 (1415)	2100 (955)		
	PNI31-386-25-7F			62.5 (1588)	2050 (932)		
	PVI31-386-12-7F			75.8 (1925)	2100 (955)		
35	PNI31-396-12-7F			62.5 (1588)	2050 (932)		
	PVI31-396-12-7F			91.0 (2311)	2450 (1114)		

Two Position, Front Access, Puffer Vacuum Interrupters

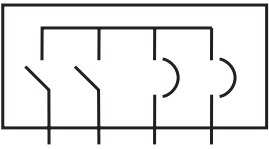
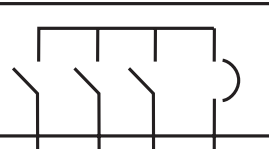
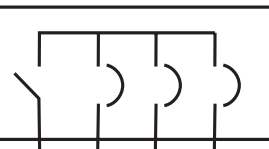
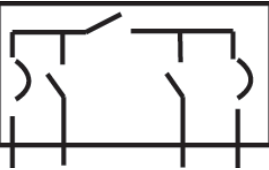
Model	One-line Diagram	Voltage kV	Catalog Number	Width in. (mm)	Weight w/Gas lbs. (kgs)		
9F		15	RPFI42-376-12-9F	62.1 (1578)	1800 (817)		
			LPFI42-376-12-9F	68.3 (1734)	2100 (955)		
			PNI42-376-25-9F	77.5 (1969)	2300 (1045)		
			PVI42-376-12-9F	88.3 (2242)	2400 (1091)		
		25	RPFI42-386-12-9F	62.1 (1578)	1800 (817)		
			LPFI42-386-12-9F	68.3 (1734)	2100 (955)		
			PNI42-386-25-9F	77.5 (1969)	2300 (1045)		
			PVI42-386-12-9F	88.3 (2242)	2400 (1091)		
		35	PNI42-396-12-9F	77.5 (1969)	2300 (1045)		
			PVI42-396-12-9F	103.5 (2629)	2700 (1227)		
		11F		15	RPFI43-376-12-11F	62.1 (1578)	1800 (817)
					LPFI43-376-12-11F	68.8 (1746)	2075 (943)
PNI43-376-25-11F	77.5 (1969)				2400 (1091)		
PVI43-376-12-11F	79.8 (2026)				2200 (1000)		
25	RPFI43-386-12-11F			62.1 (1578)	1800 (817)		
	LPFI43-386-12-11F			68.8 (1746)	2075 (943)		
	PNI43-386-25-11F			77.5 (1969)	2400 (1091)		
	PVI43-386-12-11F			79.8 (2026)	2200 (1000)		
35	PNI43-396-12-11F			77.5 (1969)	2400 (1091)		
	PVI43-396-12-11F			86.0 (2184)	2450 (1114)		
12F				15	RPFI41-376-12-12F	62.1 (1578)	1800 (817)
					LPFI41-376-12-12F	67.8 (1721)	2150 (977)
		PNI41-376-25-12F	77.5 (1969)		2400 (1091)		
		PVI41-376-12-12F	96.8 (2459)		2600 (1182)		
		25	RPFI41-386-12-12F	62.1 (1578)	1800 (817)		
			LPFI41-386-12-12F	67.8 (1721)	2150 (977)		
			PNI41-386-25-12F	77.5 (1969)	2400 (1091)		
			PVI41-386-12-12F	95.0 (2413)	2600 (1182)		
		35	PNI41-396-12-12F	77.5 (1969)	2400 (1091)		
			PVI41-396-12-12F	121.0 (3073)	3000 (1364)		
		43F	 <i>Bus Tie</i>	15	RPFI43-376-12-43F-BT	74.1 (1883)	2100 (953)
					LPFI43-376-12-43F-BT	80.2 (2037)	2300 (1045)
PNI43-376-25-43F-BT	92.5 (2350)				2750 (1250)		
PVI43-376-12-43F-BT	101 (2565)				2700 (1227)		
25	RPFI43-386-12-43F-BT			74.2 (1885)	2250 (1023)		
	LPFI43-386-12-43F-BT			80.2 (2037)	2300 (1045)		
	PNI43-386-25-43F-BT			92.5 (2350)	2750 (1250)		
	PVI43-386-12-43F-BT			101 (2565)	2700 (1227)		
35	PNI43-396-12-43F-BT			92.5 (2350)	2750 (1250)		

Two Position, Front Access, Puffer Vacuum Interrupters

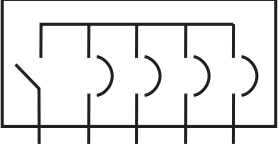
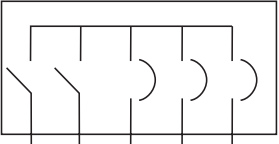
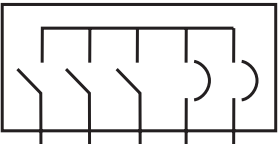
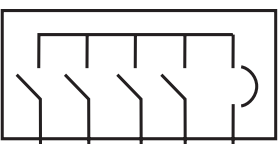
Model	One-line Diagram	Voltage kV	Catalog Number	Width in. (mm)	Weight w/Gas lbs. (kgs)
51F		15	RPF151-376-12-51F	74.1 (1883)	2300 (1044)
			LPFI51-376-12-51F	79.7 (2025)	2600 (1182)
			PNI51-376-25-51F	92.5 (2350)	2900 (1318)
			PVI51-376-12-51F	118 (2997)	3100 (1409)
		25	RPF151-386-12-51F	74.2 (1885)	2250 (1023)
			LPFI51-386-12-51F	79.7 (2025)	2600 (1182)
			PNI51-386-25-51F	92.5 (2350)	2900 (1318)
			PVI51-386-12-51F	118 (2997)	3100 (1409)
		35	PNI51-396-12-51F	92.5 (2350)	2900 (1318)
			PVI51-396-12-51F	151 (3835)	3600 (1636)
52F		15	RPF152-376-12-52F	74.1 (1883)	2100 (953)
			LPFI52-376-12-52F	80.3 (2038)	2525 (1148)
			PNI52-376-25-52F	92.5 (2350)	2800 (1273)
			PVI52-376-12-52F	109.3 (2776)	2900 (1318)
		25	RPF152-386-12-52F	74.1 (1883)	2100 (953)
			LPFI52-386-12-52F	80.3 (2038)	2525 (1148)
			PNI52-386-25-52F	92.5 (2350)	2800 (1273)
			PVI52-386-12-52F	109.3 (2775)	2900 (1318)
		35	PNI52-396-12-52F	92.5 (2350)	2800 (1273)
			PVI52-396-12-52F	133.5 (3391)	3250 (1477)
53F		15	RPF153-376-12-53F	74.1 (1883)	2100 (953)
			LPFI53-376-12-53F	80.8 (2051)	2450 (1114)
			PNI53-376-25-53F	92.5 (2350)	2750 (1250)
			PVI53-376-12-53F	101 (2565)	2700 (1227)
		25	RPF153-386-12-53F	74.1 (1883)	2100 (953)
			LPFI53-386-12-53F	80.8 (2051)	2450 (1114)
			PNI53-386-25-53F	92.5 (2350)	2750 (1250)
			PVI53-386-12-53F	101 (2565)	2700 (1227)
		35	PNI53-396-12-53F	92.5 (2350)	2750 (1250)
			PVI53-396-12-53F	116 (2946)	3000 (1364)
54F		15	RPF154-376-12-54F	74.1 (1883)	2000 (908)
			LPFI54-376-12-54F	81.3 (2064)	2400 (1091)
			PNI54-376-25-54F	92.5 (2350)	2650 (1205)
			PVI54-376-12-54F	93 (2362)	2500 (1136)
		25	RPF154-386-12-54F	74.1 (1883)	2000 (908)
			LPFI54-386-12-54F	81.3 (2064)	2400 (1091)
			PNI54-386-25-54F	92.5 (2350)	2650 (1205)
			PVI54-386-12-54F	93 (2362)	2500 (1136)
		35	PNI54-396-12-54F	92.5 (2350)	2650 (1205)
			PVI54-396-12-54F	98.5 (2502)	2700 (1227)

Two Position, Front Access, Puffer Vacuum Interrupters

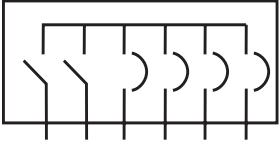
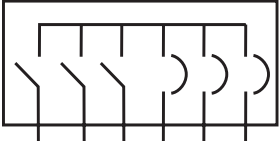
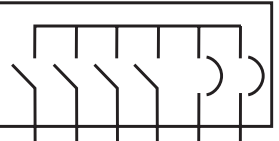
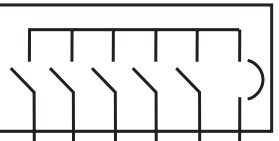
Model	One-line Diagram	Voltage kV	Catalog Number	Width in. (mm)	Weight w/Gas lbs. (kgs)		
62F		15	RPF162-376-12-62F	86.1 (2188)	2400 (1089)		
			LPF162-376-12-62F	92.3 (2343)	2800 (1273)		
			PNI62-376-25-62F	107.5 (2731)	3300 (1500)		
			PVI62-376-12-62F	130.3 (3308)	3400 (1545)		
		25	RPF162-386-12-62F	86.1 (2188)	2400 (1089)		
			LPF162-386-12-62F	92.3 (2343)	2800 (1273)		
			PNI62-386-25-62F	107.5 (2731)	3300 (1500)		
			PVI62-386-12-62F	130.3 (3310)	3400 (1545)		
		35	PNI62-396-12-62F	107.5 (2731)	3300 (1500)		
		63F		15	RPF163-376-12-63F	86.1 (2188)	2400 (1089)
					LPF163-376-12-63F	92.8 (2356)	2750 (1250)
PNI63-376-25-63F	107.5 (2731)				3200 (1455)		
PVI63-376-12-63F	122 (3099)				3200 (1455)		
25	RPF163-386-12-63F			86.1 (2188)	2400 (1089)		
	LPF163-386-12-63F			92.8 (2356)	2750 (1250)		
	PNI63-386-25-63F			107.5 (2731)	3200 (1455)		
	PVI63-386-12-63F			122 (3099)	3200 (1455)		
35	PNI63-396-12-63F			107.5 (2731)	3200 (1455)		
	PNI63-396-12-63F			107.5 (2731)	3200 (1455)		
64F				15	RPF164-376-12-64F	86.1 (2188)	2300 (1044)
					LPF164-376-12-64F	93.3 (2369)	2700 (1227)
		PNI64-376-25-64F	107.5 (2731)		3100 (1409)		
		PVI64-376-12-64F	113 (2870)		3000 (1364)		
		25	RPF164-386-12-64F	86.1 (2188)	2300 (1044)		
			LPF164-386-12-64F	93.3 (2369)	2700 (1227)		
			PNI64-386-25-64F	107.5 (2731)	3100 (1409)		
			PNI64-386-25-64F	107.5 (2731)	3100 (1409)		
		35	PNI64-396-12-64F	107.5 (2731)	3100 (1409)		
			PVI64-396-12-64F	129 (3277)	3300 (1500)		
		65F		15	RPF165-376-12-65F	86.1 (2188)	2300 (1044)
					LPF165-376-12-65F	93.7 (2381)	2650 (1205)
PNI65-376-25-65F	107.5 (2731)				3000 (1364)		
PVI65-376-12-65F	105 (2667)				2800 (1273)		
25	RPF165-386-12-65F			86.1 (2188)	2300 (1044)		
	LPF165-386-12-65F			93.7 (2381)	2650 (1205)		
	PNI65-386-25-65F			107.5 (2731)	3000 (1364)		
	PVI65-386-12-65F			105 (2667)	2800 (1273)		
35	PNI65-396-12-65F			107.5 (2731)	3000 (1364)		
	PVI65-396-12-65F			111 (2819)	3000 (1364)		

Two Position, Front Access, Puffer Vacuum Interrupters

Model	One-line Diagram	Voltage kV	Catalog Number	Width in. (mm)	Weight w/Gas lbs. (kgs)
72F		15	RPF172-376-12-72F	98.1 (2493)	2500 (1136)
			LPF172-376-12-72F	104.3 (2648)	3100 (1409)
			PNI72-376-25-72F	122.5 (3112)	3850 (1750)
			PVI72-376-12-72F	151.3 (3842)	3850 (1750)
		25	RPF172-386-12-72F	98.1 (2493)	2500 (1136)
			LPF172-386-12-72F	104.3 (2648)	3100 (1409)
			PNI72-386-25-72F	122.5 (3112)	3850 (1750)
			PVI72-386-12-72F	151.3 (3842)	3850 (1750)
		35	PNI72-396-12-72F	122.5 (3112)	3850 (1750)

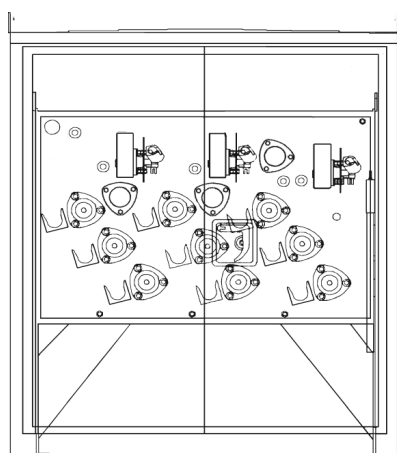

Manually operated RPF1-6F shown.

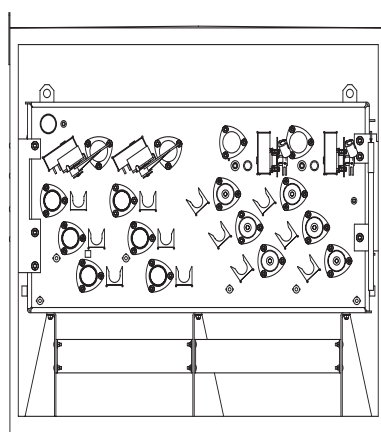

Model LPF1-9F shown

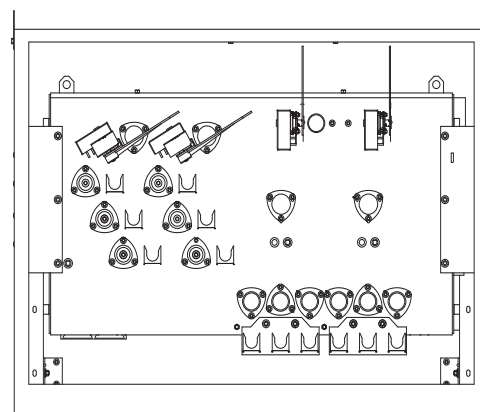

Model PNI-9F Shown with diagonal bushing configuration.

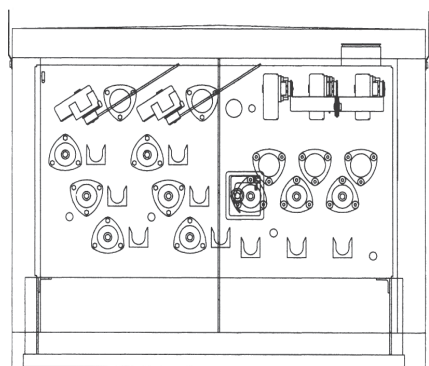

Model PVI-6F front, shown with three phase operating handle

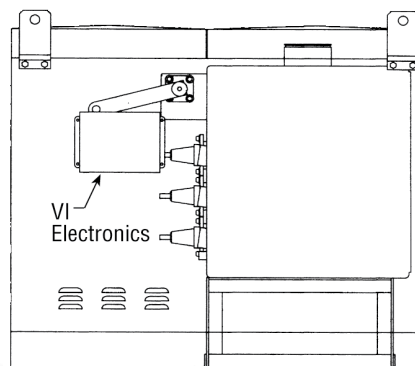

Model PVI-6F side

Load and Fault Interrupting Switches

Two Position, Front / Back Access, PVI Style, Puffer Vacuum Interrupters

Provides front and back compartments for separating source and tap cables. Load break switch operating mechanisms are located on the sides of the switch. Fault interrupters can be changed from single phase to three phase protection in the field. Provides load break switch visible break with 12 or 20kA symmetrical single or three phase fault interrupting.

Load break switch (LP) ratings			
Maximum Design Voltage kV	15.5	27	38
Voltage class, kV	15	25	38
Impulse level (BIL), kV	110	125	150
One minute withstand, AC kV	35	60	70
One minute withstand, Production test rating, AC kV	34	40	50
15 minute withstand, DC kV	53	78	103
Continuous and load break current, Amps*	630	630	630
Momentary current, kA asym	40	40	40
Fault-close current, (3 times) kA asym	40	40	40
One second current, kA sym	25	25	25
Open gap withstand, kV	200	200	200
10 operation overload interrupting capability, Amps	3000	3000	3000
Operations load interrupting at 600A	1200	1200	1200
Mechanical endurance, operations	2000	2000	2000
Fault interrupter (VI) ratings			
Maximum design voltage kV	15.5	27	38
Voltage class, kV	15	25	35
Impulse level (BIL), kV	95	125	150
One minute withstand, AC kV	50	60	70
One minute withstand, Production test rating, AC kV	34	40	50
15 minute withstand, DC kV	53	78	103
Continuous and load break current, Amps	630	630	630
Symmetrical interrupting rating, kA)**	12	12	12

*900A continuous available.

**20kA available

IEEE C37.60 Fault Interrupting Duty for 12kA current rated

Total number of fault interruptions: 116		
Percent of Maximum Interrupting Rating	Approx. Interrupting Current, Amps	No. of Fault Interruptions
15-20%	2,000	44
45-55%	6,000	56
90-100%	12,000	16



Model PVI-9 front view.



Model PVI-9 rear view.

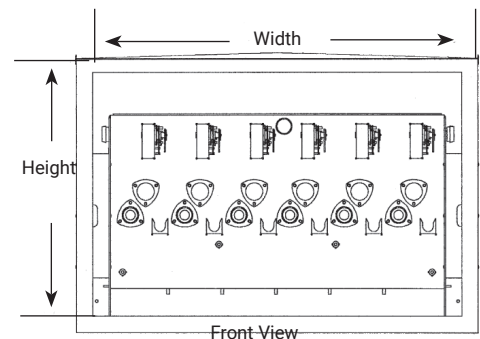

Front View

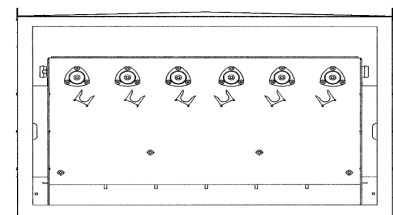

Back View

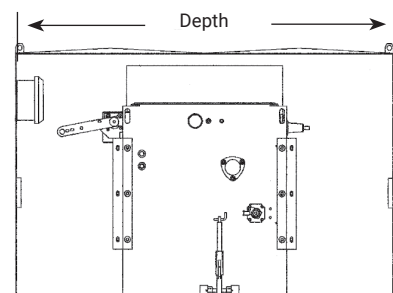

Side View

Front / Back Access PVI Puffer Vacuum Interrupters

Model	One-line Diagram	Voltage kV	Catalog Number	Approximate		
				Width in. (mm)	Depth in. (mm)	Weight w/Gas lbs. (kgs)
3		15	PPI21-376-40-3	44.5 (1130)	79 (2007)	950 (432)
		25	PPI21-386-40-3	44.5 (1130)	79 (2007)	950 (432)
		35	PPI21-396-40-3	44.5 (1130)	79 (2007)	950 (432)
4		15	PVI20-376-12-4	44.5 (1130)	79 (2007)	950 (432)
		25	PVI20-386-12-4	44.5 (1130)	79 (2007)	950 (432)
		35	PVI20-396-12-4	44.5 (1130)	79 (2007)	950 (432)
5		15	PVI21-376-12-5	44.5 (1130)	79 (2007)	950 (432)
		25	PVI21-386-12-5	44.5 (1130)	79 (2007)	950 (432)
		35	PVI21-396-12-5	44.5 (1130)	79 (2007)	950 (432)
6		15	PVI32-376-12-6	74.0 (1880)	79 (2007)	2250 (1023)
		25	PVI32-386-12-6	74.0 (1880)	79 (2007)	2250 (1023)
		35	PVI32-396-12-6	74.0 (1880)	79 (2007)	2250 (1023)
7		15	PVI31-376-12-7	74.0 (1880)	79 (2007)	2250 (1023)
		25	PVI31-386-12-7	74.0 (1880)	79 (2007)	2250 (1023)
		35	PVI31-396-12-7	74.0 (1880)	79 (2007)	2250 (1023)
8		15	PVI41-376-12-8	74.0 (1880)	79 (2007)	2250 (1023)
		25	PVI41-386-12-8	74.0 (1880)	79 (2007)	2250 (1023)
		35	PVI41-396-12-8	74.0 (1880)	79 (2007)	2250 (1023)
9		15	PVI42-376-12-9	74.0 (1880)	79 (2007)	2300 (1043)
		25	PVI42-386-12-9	74.0 (1880)	79 (2007)	2300 (1043)
		35	PVI42-396-12-9	74.0 (1880)	79 (2007)	2300 (1043)
10		15	PPI44-376-40-10	74.0 (1880)	79 (2007)	2200 (998)
		25	PPI44-386-40-10	74.0 (1880)	79 (2007)	2200 (998)
		35	PPI44-396-40-10	74.0 (1880)	79 (2007)	2200 (998)
11		15	PVI43-376-12-11	74.0 (1880)	79 (2007)	2400 (1091)
		25	PVI43-386-12-11	74.0 (1880)	79 (2007)	2400 (1091)
		35	PVI43-396-12-11	74.0 (1880)	79 (2007)	2400 (1091)
12		15	PVI41-376-12-12	74.0 (1880)	79 (2007)	2400 (1091)
		25	PVI41-386-12-12	74.0 (1880)	79 (2007)	2400 (1091)
		35	PVI41-396-12-12	74.0 (1880)	79 (2007)	2400 (1091)
13		15	PPI33-376-40-13	74.0 (1880)	79 (2007)	2350 (1066)
		25	PPI33-386-40-13	74.0 (1880)	79 (2007)	2350 (1066)
		35	PPI33-396-40-13	74.0 (1880)	79 (2007)	2350 (1066)
14		15	PVI42-376-12-14	74.0 (1880)	79 (2007)	2250 (1023)
		25	PVI42-386-12-14	74.0 (1880)	79 (2007)	2250 (1023)
		35	PVI42-396-12-14	74.0 (1880)	79 (2007)	2250 (1023)

Enclosure height is 50" (1270mm).

Load and Fault Interrupting Switches

Two Position, Front / Back Access, PNI-L Style, Puffer Vacuum Interrupters

Provides front and back compartments for separating all operating mechanisms from the source and tap cables and provides load break switch visible break with 25kA symmetrical interrupting.

Load break switch (LP) ratings			
Maximum Design Voltage kV	15.5	27	38
Voltage class, kV	15	25	35
Impulse level (BIL), kV	110	125	150
One minute withstand, AC kV	35	60	70
One minute withstand, Production test rating, AC kV	34	40	50
15 minute withstand, DC kV	53	78	103
Continuous and load break current, Amps*	630	630	630
Momentary current, kA asym	40	40	40
Fault-close current, (3 times) kA asym	40	40	40
One second current, kA sym	25	25	25
Open gap withstand, kV	200	200	200
10 operation overload interrupting capability, Amps	3000	3000	3000
Operations load interrupting at 600A	1200	1200	1200
Mechanical endurance, operations	2000	2000	2000
Fault interrupter (VI) ratings			
Maximum Design Voltage kV	15.5	27	38
Voltage class, kV	15	25	35
Impulse level (BIL), kV	95	125	150
One minute withstand, AC kV	50	60	70
One minute withstand, Production test rating, AC kV	34	40	50
15 minute withstand, DC kV	53	78	103
Continuous and load break current, Amps	630	630	630
Symmetrical interrupting rating, kA**	12	12	12

*900A continuous available.

**25kA available

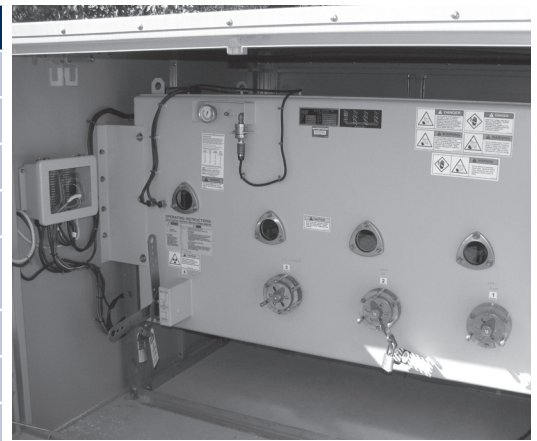

Front view of a padmount PNI-43L with rotary style load break operator.



Back view of a padmount PNI-43L with rotary style load break operator.

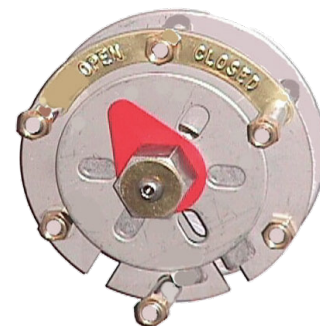

Optional load break rotary style operator.

IEEE C37.60 Fault Interrupting Duty for 12kA current rated

Total number of fault interruptions: 116		
Percent of Maximum Interrupting Rating	Approx. Interrupting Current, Amps	No. of Fault Interruptions
15-20%	2,000	44
45-55%	6,000	56
90-100%	12,000	16

Two Position, Front / Back Access, PNI-L Style, Puffer Vacuum Interrupters

Model	One-line Diagram	Voltage kV	Catalog Number	Approximate	
				Width in. (mm)	Weight w/Gas lbs. (kgs)
4		15	PNI20-376-12-4L	47.5 (1206)	1650 (750)
		25	PNI20-386-12-4L		
		35	PNI20-396-12-4L		
6		15	PNI32-376-12-6L	62.5 (1588)	2050 (932)
		25	PNI32-386-12-6L		
		35	PNI32-396-12-6L		
7		15	PNI31-376-12-7L	62.5 (1588)	2050 (932)
		25	PNI31-386-12-7L		
		35	PNI31-396-12-7L		
9		15	PNI42-376-12-9L	77.5 (1969)	2500 (1136)
		25	PNI42-386-12-9L		
		35	PNI42-396-12-9L		
11		15	PNI43-376-12-11L	77.5 (1969)	2500 (1136)
		25	PNI43-386-12-11L		
		35	PNI43-396-12-11L		
12		15	PNI41-376-12-12L	77.5 (1969)	2500 (1136)
		25	PNI41-386-12-12L		
		35	PNI41-396-12-12L		
51		15	PNI51-376-12-51L	92.5 (2350)	3350 (1522)
		25	PNI51-386-12-51L		
		35	PNI51-396-12-51L		
52		15	PNI52-376-12-52L	92.5 (2350)	3350 (1522)
		25	PNI52-386-12-52L		
		35	PNI52-396-12-52L		
53		15	PNI53-376-12-53L	92.5 (2350)	3350 (1522)
		25	PNI53-386-12-53L		
		35	PNI53-396-12-53L		
54		15	PNI54-376-12-54L	92.5 (2350)	3350 (1522)
		25	PNI54-386-12-54L		
		35	PNI54-396-12-54L		
62		15	PNI62-376-12-62L	107.5 (2731)	3350 (1522)
		25	PNI62-386-12-62L		
		35	PNI62-396-12-62L		
63		15	PVI42-376-12-14	107.5 (2731)	3350 (1522)
		25	PVI42-386-12-14		
		35	PVI42-396-12-14		

Two Position, Front / Back Access, PNI-L Style, Puffer Vacuum Interrupters

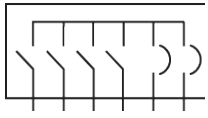
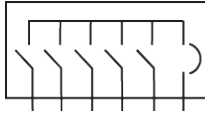
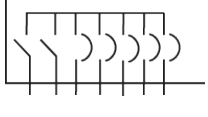
Model	One-line Diagram	Voltage kV	Catalog Number	Approximate	
				Width in. (mm)	Weight w/Gas lbs. (kgs)
64		15	PNI64-376-12-64L	107.5 (2731)	3350 (1522)
		25	PNI64-386-12-64L		
		35	PNI64-396-12-64L		
65		15	PNI65-376-12-65L	107.5 (2731)	3350 (1522)
		25	PNI65-386-12-65L		
		35	PNI65-396-12-65L		
72		15	PNI72-376-12-72L	122.5 (3111)	4000 (1818)
		25	PNI72-386-12-72L		
		35	PNI72-396-12-72L		

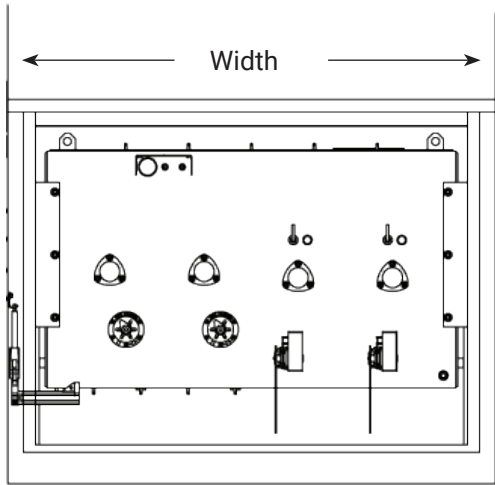

Front View

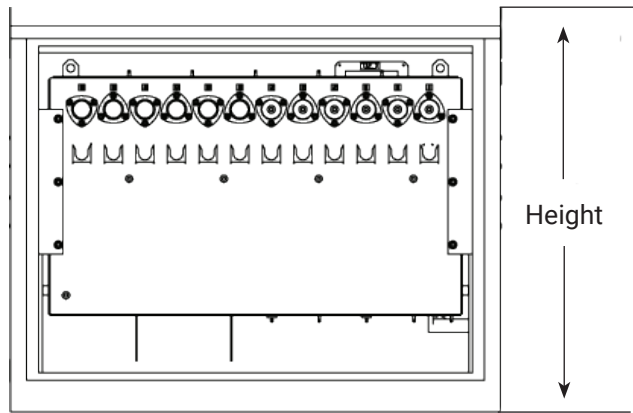

Back View

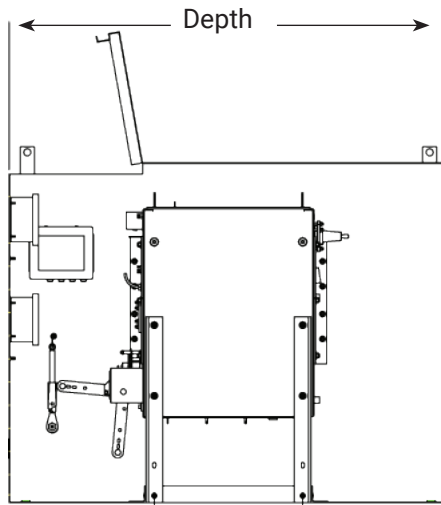

Load and Fault Interrupting Switches

Three Position, Front Access TFI with Load Break Ground Switches

Switches incorporate rotary puffer style internal ground for the load break switch ways. Two models offer different ratings and vacuum interrupter capabilities. Model TFI provides three phase protection.

Load break switch (RP) ratings		
Maximum Design Voltage kV	15.5	27
Voltage class, kV	15	25
Impulse level (BIL), kV	110	125
One minute withstand, AC kV	35	60
One minute withstand, Production test rating, AC kV	34	40
15 minute withstand, DC kV	53	78
Continuous and load break current, Amps	630	630
Momentary current, kA asym	40	40
Fault-close current, (3 times) kA asym	32	32
One second current, kA sym	25	25
Mechanical endurance, operations	2000	2000
Fault interrupter (FI) ratings		
Maximum Design Voltage kV	15.5	27
Voltage class, kV	15	25
Impulse level (BIL), kV	110	125
One minute withstand, AC kV	50	60
One minute withstand, Production test rating, AC kV	34	40
15 minute withstand, DC kV	53	78
Continuous and load break current, Amps	630	630
Symmetrical interrupting rating, kA*	12.5	12.5

*15.5kV available at 16kA sym. interrupting current

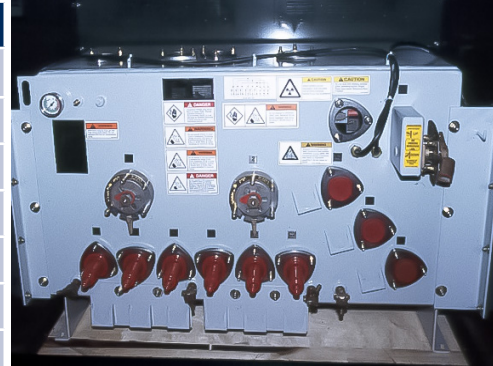

TFI-6F

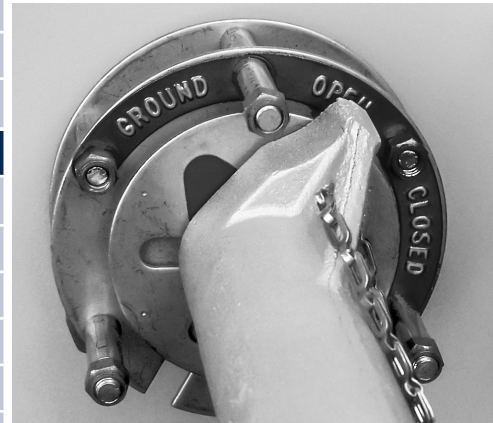

Load break multi-position switch operator.

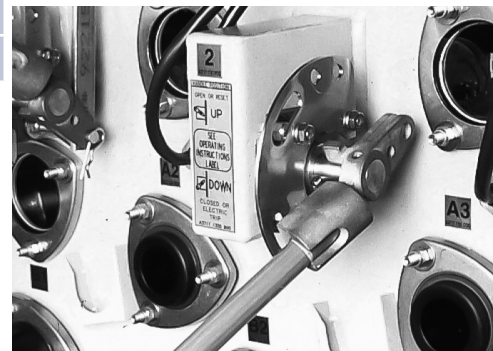

Fault interrupter operating handle.

IEEE C37.60 Fault Interrupting Duty for 12.5kA current rated

Total number of fault interruptions: 116		
Percent of Maximum Interrupting Rating	Approx. Interrupting Current, Amps	No. of Fault Interruptions
15-20%	2,000	44
45-55%	6,000	56
90-100%	12,500	16

Load and Fault Interrupting Switches

Three Position, Front or Front/Back Access TVI with Load Break Ground Switches

Switches incorporate rotary puffer style internal ground for the load break switch ways. Model TVI provides single phase or three phase protection, with 12 or 20kA symmetrical interrupting.

Load break switch (RP) ratings			
Maximum Design Voltage kV	15.5	27	38
Voltage class, kV	15	25	35
Impulse level (BIL), kV	110	125	150
One minute withstand, AC kV	35	60	70
One minute withstand, Production test rating, AC kV	34	40	50
15 minute withstand, DC kV	53	78	103
Continuous and load break current, Amps	630	630	630
Momentary current, kA asym	40	40	40
Fault-close current, (3 times) kA asym	32	32	32
One second current, kA sym	20	20	20
Mechanical endurance, operations	2000	2000	2000
Fault interrupter (VI) ratings			
Maximum design voltage, kV	15.5	27	38
Voltage class	15	25	35
Impulse level (BIL)	95	125	150
One minute withstand, AC kV	50	60	70
One minute withstand, production test rating AC kV	34	40	50
15 minute withstand, DC kV	53	78	103
Continuous and load break current, Amps	630	630	630
Symmetrical interrupting rating, kA**	12	12	12



Front Access



Front view of Front/Back Access



Back view of Front/Back access

**20kA available



Single phase interrupter operating handles.

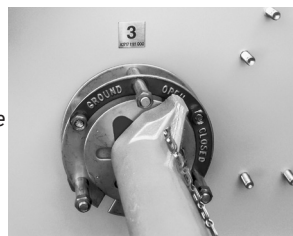

Load break multi-position switch operator.

IEEE C37.60 Fault Interrupting Duty for 12kA current rated

Total number of fault interruptions: 116

Percent of Maximum Interrupting Rating	Approx. Interrupting Current, Amps	No. of Fault Interruptions
15-20%	2,000	44
45-55%	6,000	56
90-100%	12,000	16

Three Position, Front Access TVI with Load Break Ground Switches

Model	One-line Diagram	Voltage kV	Catalog Number	Approximate		Weight w/Gas lbs. (kgs)
				Width in. (mm)	Depth	
6F		15	TVI32-376-12-6F	67.9 (1725)	55 (1397)	1700 (773)
			TFI32-376-12-6F	55.6 (1413)	55 (1397)	1350 (612)
		25	TVI32-386-12-6F	71 (1803)	55 (1397)	1550 (705)
			TFI32-386-12-6F	55.6 (1413)	55 (1397)	1350 (612)
		35	TVI32-396-12-6F	80 (2032)	55 (1397)	1350 (612)
		9F		15	TVI42-376-12-9F	92 (2337)
TFI42-376-12-9F	68 (1727)				55 (1397)	2200 (1000)
25	TVI42-386-12-9F			92 (2337)	55 (1397)	2200 (1000)
	TFI42-386-12-9F			68 (1727)	55 (1397)	2200 (1000)
35	TVI42-396-12-9F			112 (2845)	55 (1397)	2400 (1090)
52F				15	TVI52-376-12-52F	113 (2870)
		TFI52-376-12-52F	76.1 (1934)		55 (1397)	2800 (1273)
		25	TVI52-386-12-52F	113 (2870)	55 (1397)	2450 (1112)
			TFI52-386-12-52F	76.1 (1934)	55 (1397)	2800 (1273)
		35	TVI52-396-12-52F	143 (3632)	55 (1397)	2850 (1294)
		62F		15	TVI62-376-12-62F	134 (3404)
TFI62-376-12-62F	95.2 (2417)				55 (1397)	3050 (1386)
25	TVI62-386-12-62F			134 (3404)	55 (1397)	2700 (1226)
	TFI62-386-12-62F			92 (2337)	55 (1397)	3050 (1386)
35	TVI62-396-12-62F			173 (4394)	55 (1397)	3400 (1544)

Height of enclosure = 50" (1270mm).

For typical specifications, go to: gwelec.com/specs.html.
For contact principle, see pages 30, 31 and 34.

Dimensions are approximate.
Do not use for construction.

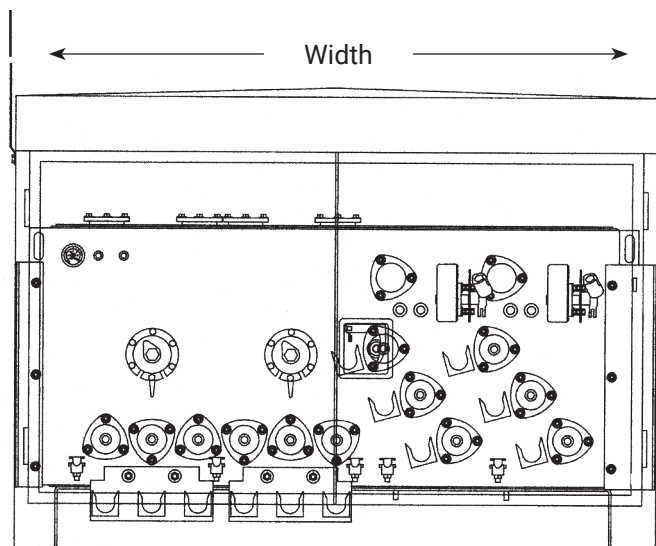

Front View

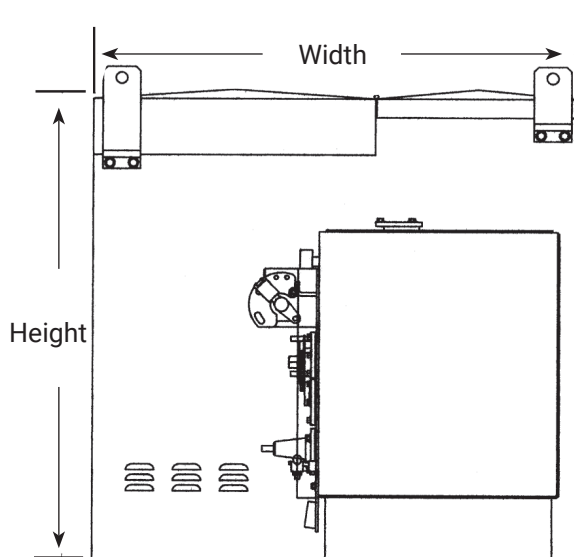

Side View

Load and Fault Interrupting Switches

Three Position, Front / Back Access, TVI with Load Break Ground Switches

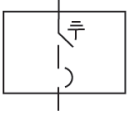
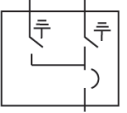
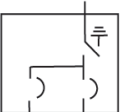
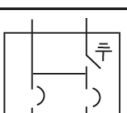
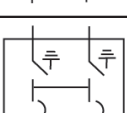
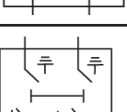
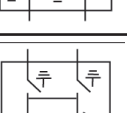
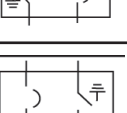
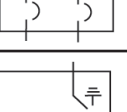
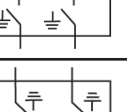
Model	One-line Diagram	Voltage kV	Catalog Number	Approximate		
				Width in. (mm)	Depth in. (mm)	Weight w/Gas lbs. (kgs)
5		15	TVI21-376-12-5	44.5 (1130)	79 (2007)	850 (386)
		25	TVI21-386-12-5	44.5 (1130)	79 (2007)	850 (386)
		35	TVI21-396-12-5	44.5 (1130)	79 (2007)	850 (386)
6		15	TVI32-376-12-6	74 (1880)	79 (2007)	1700 (773)
		25	TVI32-386-12-6	74 (1880)	79 (2007)	1700 (773)
		35	TVI32-396-12-6	74 (1880)	79 (2007)	1700 (773)
7		15	TVI31-376-12-7	74 (1880)	79 (2007)	2000 (909)
		25	TVI31-386-12-7	74 (1880)	79 (2007)	2000 (909)
		35	TVI31-396-12-7	74 (1880)	79 (2007)	2000 (909)
8		15	TVI41-376-12-8	74 (1880)	79 (2007)	2300 (1045)
		25	TVI41-386-12-8	74 (1880)	79 (2007)	2300 (1045)
		35	TVI41-396-12-8	74 (1880)	79 (2007)	2300 (1045)
9		15	TVI42-376-12-9	74 (1880)	79 (2007)	2300 (1045)
		25	TVI42-386-12-9	74 (1880)	79 (2007)	2300 (1045)
		35	TVI42-396-12-9	74 (1880)	79 (2007)	2300 (1045)
10		15	T44-376-40-10	74 (1880)	79 (2007)	2200 (1000)
		25	T44-386-40-10	74 (1880)	79 (2007)	2200 (1000)
		35	T44-396-40-10	74 (1880)	79 (2007)	2200 (1000)
11		15	TVI43-376-12-11	74 (1880)	79 (2007)	2200 (1000)
		25	TVI43-386-12-11	74 (1880)	79 (2007)	2200 (1000)
		35	TVI43-396-12-11	74 (1880)	79 (2007)	2200 (1000)
12		15	TVI41-376-12-12	74 (1880)	79 (2007)	2400 (1091)
		25	TVI41-386-12-12	74 (1880)	79 (2007)	2400 (1091)
		35	TVI41-396-12-12	74 (1880)	79 (2007)	2400 (1091)
13		15	T33-376-40-13	74 (1880)	79 (2007)	2000 (908)
		25	T33-386-40-13	74 (1880)	79 (2007)	2000 (908)
		35	T33-396-40-13	74 (1880)	79 (2007)	2000 (908)
14		15	TVI42-376-12-14	74 (1880)	79 (2007)	2000 (908)
		25	TVI42-386-12-14	74 (1880)	79 (2007)	2000 (908)
		35	TVI42-396-12-14	74 (1880)	79 (2007)	2000 (908)

Three Position, Front / Back Access, TVI with Load Break Ground Switches

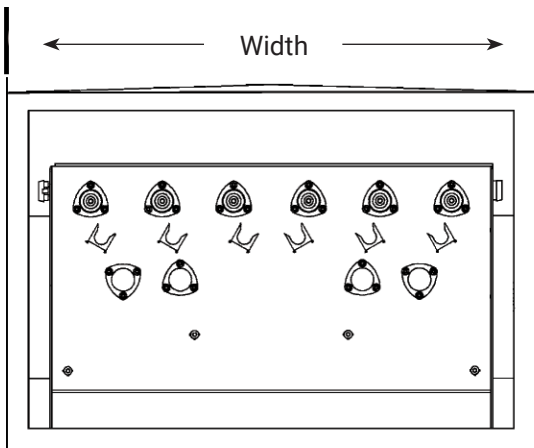

Front view showing source cable entrances.

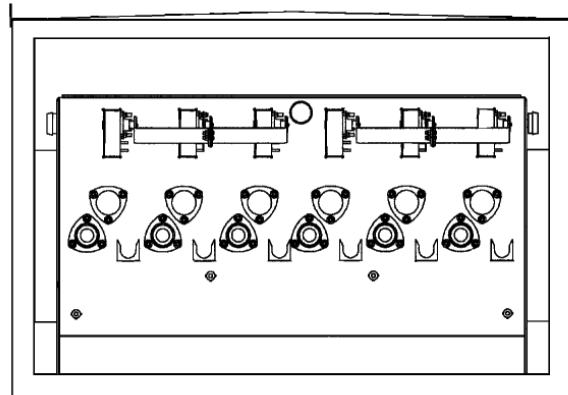

Back view showing VI cable entrances and operators.

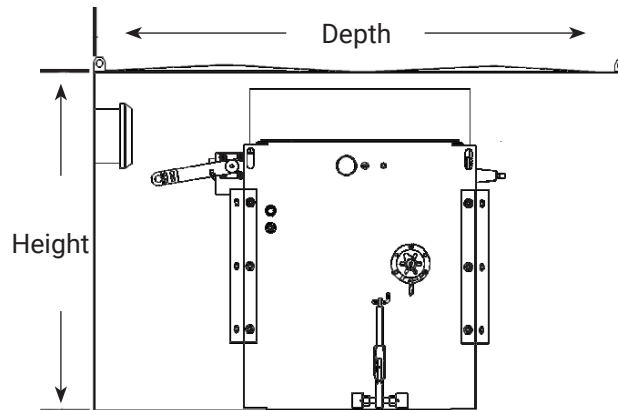

Side view showing load break operator.

Height of enclosure = 50" (1270mm)

Dimensions are approximate.
Do not use for construction.

Load and Fault Interrupting Switches

Three Position, Front / Back Access, TNI, with both Load Break and Fault Interrupter Ground Switches

Model TNI Switches incorporate rotary puffer style internal ground switching for both the load break and fault interrupter switch ways. Model NI vacuum interrupter three phase mechanisms are used.

Load break switch (RP) ratings			
Maximum Design Voltage kV	15.5	27	38
Voltage class, kV	15	25	35
Impulse level (BIL), kV	110	125	150
One minute withstand, AC kV	35	60	70
One minute withstand, Production test rating, AC kV	34	40	50
15 minute withstand, DC kV	53	78	103
Continuous and load break current, Amps	630	630	630
Momentary current, kA asym	40	40	40
Fault-close current, (3 times) kA asym	32	32	32
One second current, kA sym	25	25	25
Mechanical endurance, operations	2000	2000	2000
Fault interrupter (NI) ratings			
Maximum design voltage, kV	15.5	27	38
Voltage class	15	25	35
Impulse level (BIL)	110	125	150
One minute withstand, AC kV	50	60	70
One minute withstand, production test rating AC kV	34	40	50
15 minute withstand, DC kV	53	78	103
Continuous and load break current, Amps	630	630	630
Symmetrical interrupting rating, kA**	12.5	12.5	12.5

**20kA and 25kA available



Front view of a TNI-9L. Contact viewing windows are on the top of the switch. See viewing window option below.



Cable entrances are located on the back of the switch.

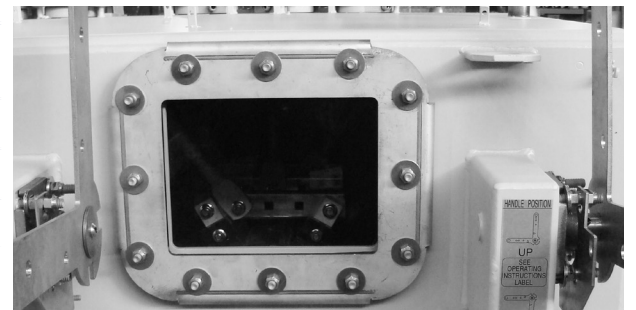

Optional large viewing window for load break switch visible break.

IEEE C37.60 Fault Interrupting Duty for 25kA current rated

Total number of fault interruptions: 116		
Percent of Maximum Interrupting Rating	Approx. Interrupting Current, Amps	No. of Fault Interruptions
15-20%	5,000	44
45-55%	12,500	56
90-100%	25,000	16

Three Position, Front / Back Access, TNI, with both Load Break and Fault Interrupter Ground Switches

Front/back access design with all operating mechanisms in the front and all cable entrances in the back compartment. Contact viewing windows are located on the top of the switch tank.

Model	One-line Diagram	Voltage kV	Catalog Number	Approximate	
				Width in. (mm)	Weight w/Gas lbs. (kgs)
5		15	TNI21-376-12-5L	51 (1295)	1725 (782)
		25	TNI21-386-12-5L	51 (1295)	1725 (782)
		35	TNI21-396-12-5L	51 (1295)	1725 (782)
6		15	TNI32-376-12-6L	69 (1753)	2900 (1315)
		25	TNI32-386-12-6L	69 (1753)	2900 (1315)
		35	TNI32-396-12-6L	69 (1753)	2900 (1315)
7		15	TNI31-376-12-7L	69 (1753)	2670 (1211)
		25	TNI31-386-12-7L	69 (1753)	2670 (1211)
		35	TNI31-396-12-7L	69 (1753)	2670 (1211)
9		15	TNI42-376-12-9L	88 (2235)	3170 (1437)
		25	TNI42-386-12-9L	88 (2235)	3170 (1437)
		35	TNI42-396-12-9L	88 (2235)	3170 (1437)
11		15	TNI43-376-12-11L	88 (2235)	3095 (1403)
		25	TNI43-386-12-11L	88 (2235)	3095 (1403)
		35	TNI43-396-12-11L	88 (2235)	3095 (1403)
12		15	TNI41-376-12-12L	88 (2235)	3245 (1471)
		25	TNI41-386-12-12L	88 (2235)	3245 (1471)
		35	TNI41-396-12-12L	88 (2235)	3245 (1471)
51		15	TNI51-376-12-51L	106 (2692)	3840 (1741)
		25	TNI51-386-12-51L	106 (2692)	3840 (1741)
		35	TNI51-396-12-51L	106 (2692)	3840 (1741)
52		15	TNI52-376-12-52L	106 (1753)	3735 (1698)
		25	TNI52-386-12-52L	106 (1753)	3735 (1698)
		35	TNI52-396-12-52L	106 (1753)	3735 (1698)
53		15	TNI53-376-12-53L	106 (1753)	3690 (3200)
		25	TNI53-386-12-53L	106 (1753)	3690 (3200)
		35	TNI53-396-12-53L	106 (1753)	3690 (3200)
54		15	TNI54-376-12-54L	106 (1753)	3690 (3200)
		25	TNI54-386-12-54L	106 (1753)	3690 (3200)
		35	TNI54-396-12-54L	106 (1753)	3690 (3200)
62		15	TNI62-376-12-62L	124 (3150)	4340 (1969)
		25	TNI62-386-12-62L	124 (3150)	4340 (1969)
		35	TNI62-396-12-62L	124 (3150)	4340 (1969)

Three Position, Front / Back Access, TNI, with both Load Break and Fault Interrupter Ground Switches

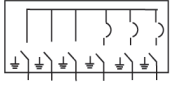
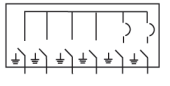
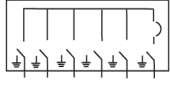
Model	One-line Diagram	Voltage kV	Catalog Number	Approximate	
				Width in. (mm)	Weight w/Gas lbs. (kgs)
63		15	TNI63-376-12-63L	124 (3150)	4265 (1935)
		25	TNI63-386-12-63L	124 (3150)	4265 (1935)
		35	TNI63-396-12-63L	124 (3150)	4265 (1935)
64		15	TNI64-376-12-64L	124 (3150)	4275 (1939)
		25	TNI64-386-12-64L	124 (3150)	4275 (1939)
		35	TNI64-396-12-64L	124 (3150)	4275 (1939)
65		15	TNI65-376-12-65L	124 (3150)	4275 (1939)
		25	TNI65-386-12-65L	124 (3150)	4275 (1939)
		35	TNI65-396-12-65L	124 (3150)	4275 (1939)

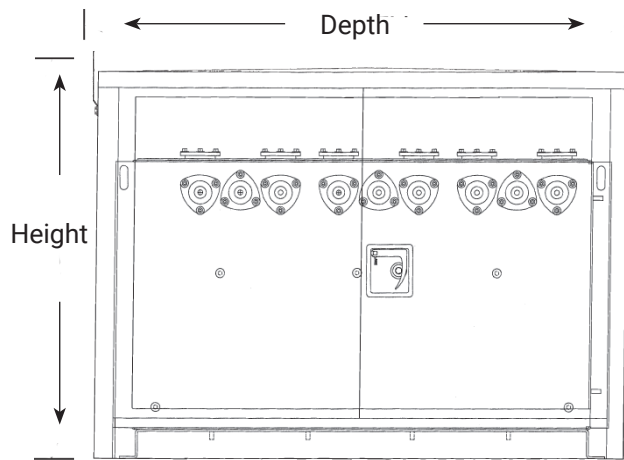

Front view showing load break and vacuum interrupter operators.

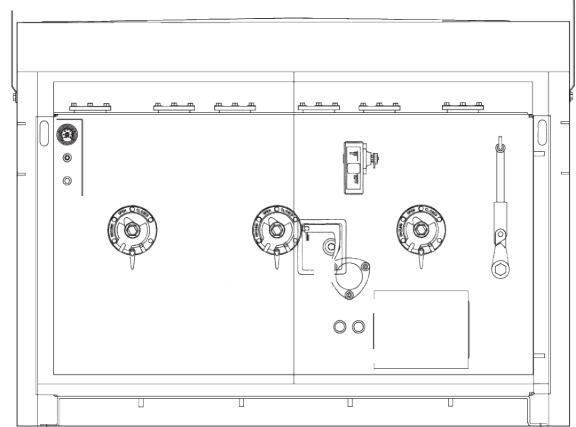

Rear view showing all cable entrances.

For typical specifications, go to: gwelec.com/specs.html

For contact principle, see pages 30 and 34.

Dimensions are approximate.

Do not use for construction.

All voltage classes have a height = 53" (1346mm); and depth = 73" (1854mm).

Two Position Load Break Switches

Two Position Load Break, Front Access, SPRAM-F / PRAM-F

Available in rotary puffer (RP) and linear puffer (PI) designs.

SPRAM-F styles provide the most compact construction due to diagonal bushing arrangements with a 6-1/2" phase spacing. These models can accommodate bushing mounted fuses. PRAM-F styles incorporate in-line bushing arrangements with a 5" phase spacing. Bushings can be top, bottom, front or side mounted.

Rotary Puffer (RP) ratings:

Maximum Design Voltage kV	15.5	27
Voltage class, kV	15	25
Impulse level (BIL), kV	110	125
One minute withstand, AC kV	35	60
One minute withstand, Production test rating, AC kV	34	40
15 minute withstand, DC kV	53	78
Continuous and load break current, Amps	630	630
Momentary current, kA asym	25.6	20
Fault-close current, (3 times) kA asym	25.6	20
One second current, kA sym	16	12.5
Operations load interrupting .. endurance (15kV) at 600A	500	350
Mechanical endurance, operations	2000	2000

Linear Puffer (PI) ratings

Maximum design voltage, kV	15.5	27	38
Voltage class	15	25	35
Impulse level (BIL)	110	125	150
One minute withstand, AC kV	35	60	70
One minute withstand, production test rating AC kV	34	40	50
15 minute withstand, DC kV	53	78	103
Continuous and load break current, Amps*	630	630	630
Momentary current, kA asym	40	40	40
Fault-close current, (3 times) kA asym	40	40	40
One second current, kA sym	25	25	25
Open gap withstand, kV	200	200	200
10 operation overload interrupting capability, Amps	3000	3000	3000
Operations load interrupting at 600A	1200	1200	1200
Mechanical endurance, operations	2000	2000	2000

*900A available

*SPRAM catalog numbers shown. For PRAM catalog numbers, remove prefix "S".

**For RP designs: Enclosure depth = 48.6" (1234mm), height = 58.7" (1491mm) based on SPRAM style. For PRAM style add up to 8" (207mm) to width dimensions.

Depth and height are the same as SPRAM style. For PI designs: Enclosure depth = 55" (1397mm), height = 46" (1168mm) based on SPRAM style. For PRAM style add 2.5" (63mm) per way to width dimensions. Depth and height are the same as SPRAM style.



Front access of SPRAM

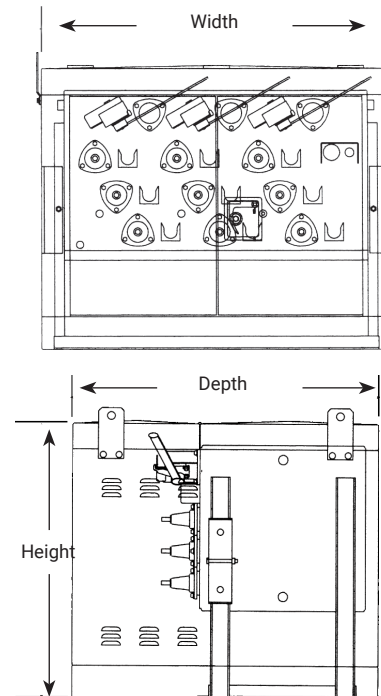

Dimensions are approximate.

Do not use for construction.

For typical specifications, go to: gwelec.com/specs.html

For contact principle, see pages 32 and 33.

SPRAM-F Two Position Load Break, Front Access

One-line Diagram Horizontal	Voltage kV	Mom. (kA) asym	Catalog Number	Approximate	
				Width in. (mm)	Weight w/Gas lbs. (kgs)
	15	25	SPRAM21-376F-25RP	38.1 (969)	1100 (499)
		40	SPRAM21-376F-40PI	41.1 (1045)	1350 (614)
	25	20	SPRAM21-386F-20RP	38.1 (969)	1100 (499)
		40	SPRAM21-386F-40PI	41.1 (1045)	1350 (614)
	35	40	SPRAM21-396F-40PI	41.1 (1045)	1350 (614)
		15	25	SPRAM33-376F-25RP	50.1 (1274)
40			SPRAM33-376F-40PI	53.8 (1365)	1700 (773)
25		20	SPRAM33-386F-20RP	50.1 (1274)	1400 (636)
		40	SPRAM33-386F-40PI	53.8 (1365)	1700 (773)
35		40	SPRAM33-396F-40PI	53.8 (1365)	1700 (773)
		15	25	SPRAM44-376F-25RP	62.1 (1578)
	40		SPRAM44-376F-40PI	66.1 (1680)	2000 (909)
	25	20	SPRAM44-386F-20RP	62.1 (1578)	1700 (772)
		40	SPRAM44-386F-40PI	66.1 (1680)	2000 (909)
	35	40	SPRAM44-396F-40PI	66.1 (1680)	2000 (909)
		15	25	SPRAM55-376F-25RP	74.1 (1883)
40			SPRAM55-376F-40PI	78.6 (1997)	2500 (1136)
25		20	SPRAM55-386F-20RP	74.1 (1883)	2000 (908)
		40	SPRAM55-386F-40PI	78.6 (1997)	2500 (1136)
35		40	SPRAM55-396F-40PI	78.6 (1997)	2500 (1136)
		15	25	SPRAM66-376F-25RP	86.1 (2187)
	40		SPRAM66-376F-40PI	91 (2311)	2600 (1182)
	25	20	SPRAM66-386F-20RP	86.1 (2187)	2200 (999)
		40	SPRAM66-386F-40PI	91 (2311)	2600 (1182)
	35	40	SPRAM66-396F-40PI	91 (2311)	2600 (1182)
		15	25	SPRAM45-376F-25RP-BT	74.2 (1885)
40			SPRAM45-376F-40PI-BT	78.5 (1991)	2000 (909)
25		20	SPRAM45-386F-20RP-BT	74.2 (1885)	2250 (1023)
		40	SPRAM45-386F-40PI-BT	78.5 (1991)	2000 (909)
35		40	SPRAM45-396F-40PI-BT	78.5 (1991)	2000 (909)

Two Position Load Break Switches

Two Position Load Break, Front / Back Access PRAM-L Style

Front / back access designs incorporate all operating mechanisms in one compartment and in-line cable entrance bushings in a separate compartment

Rotary Puffer (PI) ratings:

Maximum Design Voltage kV	15.5	27	38
Voltage class, kV	15	25	35
Impulse level (BIL), kV	110	125	150
One minute withstand, AC kV	35	60	70
One minute withstand, Production test rating, AC kV	34	40	50
15 minute withstand, DC kV	53	78	103
Continuous and load break current, Amps, 900A available	630	630	630
Momentary current, kA asym	40	40	40
Fault-close current, (3 times) kA asym	40	40	40
One second current, kA sym	25	25	25
Open gap withstand, kV	200	200	200
10 operations load interrupting capability, Amps	3000	3000	3000
Operations load interrupting at 600A	1200	1200	1200
Mechanical endurance, operations	2000	2000	2000



Front PRAM-F. Front access shown

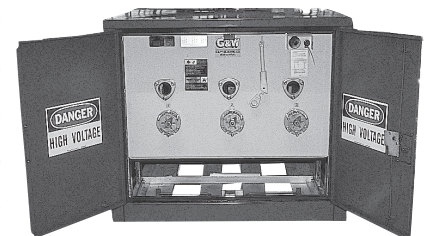

Front-back PRAM-L. Front access shown.

Two Position Load Break, Front / Back Access PRAM-L Style

One-line Diagram Horizontal	Voltage kV	Mom. (kA) asym	Catalog Number	Approximate	
				Width in. (mm)*	Weight w/Gas lbs. (kgs)
	15	40	PRAM21-376L-40PI	41 (1041)	1550 (705)
	25	40	PRAM21-386L-40PI	41 (1041)	1550 (705)
	35	40	PRAM21-396L-40PI	41 (1041)	1550 (705)
	15	40	PRAM33-376L-40PI	55 (1397)	1682 (763)
	25	40	PRAM33-386L-40PI	55 (1397)	1682 (763)
	35	40	PRAM33-396L-40PI	55 (1397)	55 (1397)
	15	40	PRAM44-376L-40PI	70 (1778)	70 (1778)
	25	40	PRAM44-386L-40PI	70 (1778)	70 (1778)
	35	40	PRAM44-396L-40PI	70 (1778)	70 (1778)
	15	40	PRAM55-376L-40PI	86 (2184)	86 (2184)
	25	40	PRAM55-386L-40PI	86 (2184)	86 (2184)
	35	40	PRAM55-396L-40PI	86 (2184)	86 (2184)
	15	40	PRAM66-376L-40PI	101 (2565)	101 (2565)
	25	40	PRAM66-386L-40PI	101 (2565)	101 (2565)
	35	40	PRAM66-396L-40PI	101 (2565)	101 (2565)

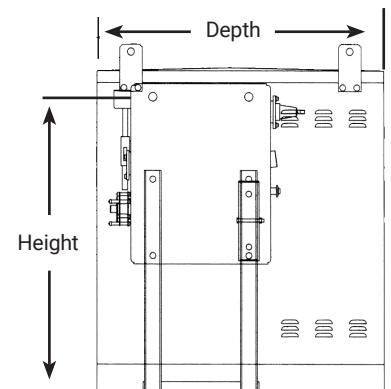

Side View

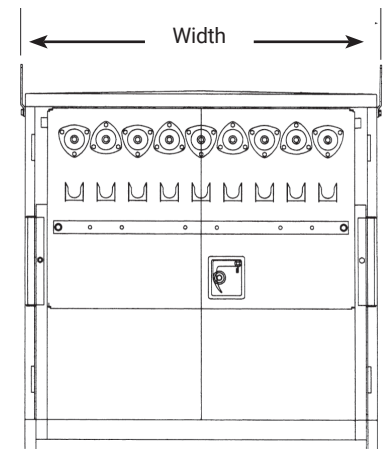

Back View

*At 15kV: Enclosure depth = 50.8" (1289mm), height = 55" (1397mm).
 At 25 & 35kV: Enclosure depth = 57.8" (1468mm), height = same.
 For typical specifications, go to: gwelec.com/specs.html

Three Position Load Break Switches

Three Position Load Break, Front Access, T-RP Style (Close-Open-Ground)

An integral ground position within the switch tank permits safe and easy grounding of the cable circuit without having to disconnect elbow or other cable entrance connections. Switching to ground is accomplished through the simple throw of the operating handle without having to de-energize other circuits through the switch. This feature is beneficial for applications where cable movement needs to be minimized. Ground stops with padlocking provisions help assure proper operation to the desired position.

Rotary Puffer (RP) ratings:			
Maximum Design Voltage kV	15.5	27	38
Voltage class, kV	15	25	35
Impulse level (BIL), kV	110	125	150
One minute withstand, AC kV	35	60	70
One minute withstand, Production test rating, AC kV	34	40	50
15 minute withstand, DC kV	53	78	103
Continuous and load break current, Amps	630	630	630
Momentary current, kA asym	40	40	40
Fault-close current, (3 times) kA asym	32	32	32
One second current, kA sym	25	25	25
Mechanical endurance, operations	2000	2000	2000

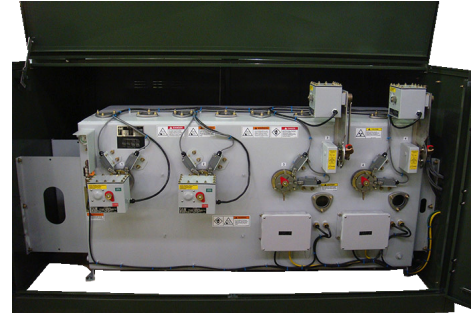

TN1 Switch- front access

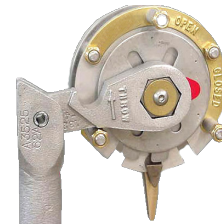

Multi-position operator and removable handle.

Three Position Load Break, Front Access, T-RP Style (Close-Open-Ground)

One-line Diagram Horizontal	Voltage kV	Mom. (kA) asym	Catalog Number	Approximate	
				Width in. (mm)*	Weight w/ Gas lbs. (kgs)
	15	40	T21-376F-40RP	45 (1143)	1400 (636)
	25	40	T21-386F-40RP	45 (1143)	1400 (636)
	35	40	T21-396F-40RP	45 (1143)	1400 (636)
	15	40	T33-376F-40RP	60 (1524)	1600 (714)
	25	40	T33-386F-40RP	60 (1524)	1600 (714)
	35	40	T33-396F-40RP	60 (1524)	1600 (714)
	15	40	T44-376F-40RP	75 (1905)	2100 (953)
	25	40	T44-386F-40RP	75 (1905)	2100 (953)
	35	40	T44-396F-40RP	75 (1905)	2100 (953)
	15	40	T55-376F-40RP	90 (2286)	2300 (1044)
	25	40	T55-386F-40RP	90 (2286)	2300 (1044)
	35	40	T55-396F-40RP	90 (2286)	2300 (1044)
	15	40	T66-376F-40RP	105 (2667)	2750 (1250)
	25	40	T66-386F-40RP	105 (2667)	2750 (1250)
	35	40	T66-396F-40RP	105 (2667)	2750 (1250)

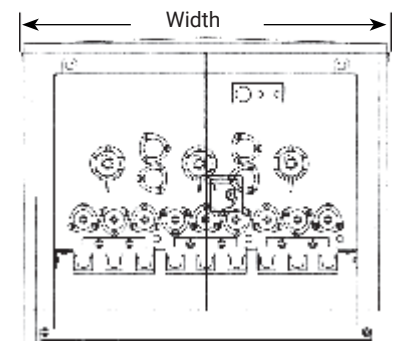

Front View

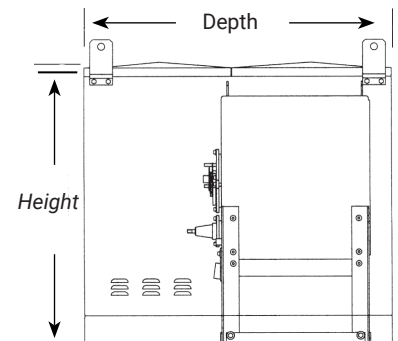

Side View

For typical specifications, go to: <https://www.gwelectric.com/resources>
 Dimensions are approximate.
 Do not use for construction.

Vacuum Interrupters Switches

Vacuum Interrupters

G&W Electric Vacuum Interrupters combine the total cost and operating benefits of fuseless, electronically controlled, resettable overcurrent protection with the safety and maintenance benefits of a totally sealed, deadfront gas insulated device. The switches are designed for automatic single or three phase fault interruption with manual load break capabilities for systems through 38kV, 630A continuous.

FI Mechanism			
Maximum Design Voltage kV	15.5	27	
Voltage class, kV	15	25	
Impulse level (BIL), kV	110	125	
One minute withstand, AC kV	50	60	
One minute withstand, Production test rating, AC kV	34	40	
15 minute withstand, DC kV	53	78	
Continuous and load break current, Amps	630	630	
Symmetrical interrupting rating, kA	12.5	12.5	
VI Mechanism			
Maximum Design Voltage kV	15.5	27	38
Voltage class, kV	15	25	35
Impulse level (BIL), kV	95	125	150
One minute withstand, AC kV	50	60	70
One minute withstand, Production test rating, AC kV	34	40	50
15 minute withstand, DC kV	53	78	103
Continuous and load break current, Amps	630	630	630
Symmetrical interrupting rating, kA (20kA available)	12	12	12
NI Mechanism			
Maximum Design Voltage kV	15.5	27	38
Voltage class, kV	15	25	35
Impulse level (BIL), kV	110	125	150
One minute withstand, AC kV	50	60	70
One minute withstand, Production test rating, AC kV	34	40	50
15 minute withstand, DC kV	53	78	103
Continuous and load break current, Amps	630	630	630
Symmetrical interrupting rating, kA (20 or 25kA avail)	12.5	12.5	12.5



Three phase model PFI with FI mechanism.

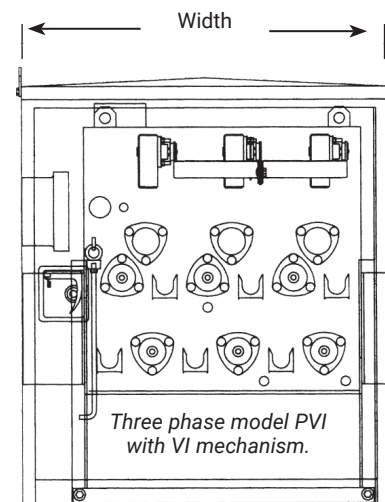

Three phase model PVI with VI mechanism.

*For 200A models, replace the "6" with 2", i.e. PVI20-172-12-4F.

† For Model PVI (single phase): At 15-35kV: Enclosure height = 38" (965mm), depth = 36" (914mm).
 For Model PVI (three phase): At 15kV: Enclosure height = 49" (1245mm), depth = 38" (965mm).
 At 25/35kV: Enclosure height = 61" (1549mm), depth = 45" (1143mm).
 For Model PFI (three phase): At 15-25kV: Enclosure height = 59" (1499mm), depth = 49" (1245mm).

For typical specifications, go to: <https://www.gwelectric.com/resources>
 Dimensions are approximate.
 Do not use for construction.

Vacuum Interrupter Switches

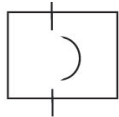
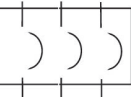
Phases	Three line diagram	Voltage Class (kV)	Amp	Catalog Number*	Approximate	
					Width In. (mm.) [†]	Wt. w/gas lbs. (kgs)
1		15	630	PVI20-176-12-4F	24.5 (622)	575 (261)
		25	630	PVI20-186-12-4F	24.5 (622)	575 (261)
		35	630	PVI20-196-12-4F	24.5 (622)	575 (261)
3		15	630	PNI20-376-25-4F	45.1 (1146)	1051 (476)
			630	PFI20-376-12-4F	38.2 (970)	1200 (545)
			630	PVI20-376-12-4F	45.8 (1163)	1000 (455)
		25	630	PNI20-386-25-4F	45.1 (1146)	1051 (476)
			630	PFI20-386-12-4F	38.2 (970)	1200 (545)
			630	PVI20-386-12-4F	45.8 (1163)	1000 (455)
		35	630	PNI20-396-12-4F	45.1 (1146)	1051 (476)
			630	PVI20-396-12-4F	52 (1321)	1150 (523)

Fault Interrupting Switches

Two Position, Front Access Fused FPRAM-F Style

G&W Electric's fused FPRAM-F style switches combine linear puffer (LP) contacts for source switches with rotary puffer (RP) contacts for fused ways. Bushings can be front or bottom mounted. For applications requiring current limitation and overcurrent interruption through 50kA symmetrical, air canister style current limiting fusing is available.

Canister Fuses

For new orders, integral air insulated, canister style current limiting fusing is available for systems through 23kV. Canister style fused switches feature compact, dead-front construction with mechanical or key interlocking arrangements preventing access to the fuses unless the switch is in the open position. Safe, quick fuse replacement is accomplished using conventional tools and without exposing switch dielectric or current carrying parts to environmental contamination. Two fuses can be connected in parallel to double the capacity rating of the switch. The general purpose fuses are IEEE C37.473.C rated and can interrupt both high and low level fault currents while limiting the available fault current on the system.

Ratings		
Maximum Design Voltage kV	15.5	27
Voltage class, kV	15	25
Impulse level (BIL), kV	110	125
One minute withstand, AC kV	35	60
One minute withstand, Production test rating, AC kV	34	40
15 minute withstand, DC kV	53	78
Continuous and load break current, Amps	630	630
Momentary current, kA asym	25.6	20
Fault-close current, (3 times) kA asym	25.6	20
One second current, kA sym	16	12.5
Operations load interrupting endurance (15kV) at 600A	500	350
Mechanical endurance, operations	2000	2000

Dimensions are approximate.

Do not use for construction.

Voltage class measured line-to-ground.

*Fuses rated above 25 Amps are required to be non-gassing fuses.

Two Position, Front Access Fused FPRAM-F Style

Air Canister Fuse Ratings		
Types of Fuseholders by Voltage Class	Single Holder Fuse Ratings	Parallel Holder Fuse Ratings
8.3kV Max. 95kV BIL	18 to 82 Amp at 4.3kV Max. 6 to 72 Amp at 5.5kV Max. 1.5 to 40 Amp at 8.3kV Max.	90 to 164 Amp at 4.3kV Max. 80 to 144 Amp at 5.5kV Max. 50 to 80 Amp at 8.3kV Max.
15.5kV Max. 125kV BIL	1.5 to 40 Amp at 15.5kV Max.	34 to 80 Amp* at 15.5kV Max.
23kV Max. 125kV BIL	6 to 29 Amp at 23kV Max.	30 to 58 Amp* at 23kV Max.

Fused FPRAM-F Switches

One line diagram	Voltage Class (kV)	Catalog Number*	Amp Max.*	Approximate	
				Width In. (mm.) [†]	Wt. w/gas lbs. (kgs)
	15	FPRAM21-376F-40PI	40	47 (1194)	750 (341)
	23	FPRAM21-386F-40PI	40	47 (1194)	750 (341)
	15	FPRAM33-376F-40PI	40	62 (1575)	1060 (482)
	23	FPRAM33-386F-40PI	40	62 (1575)	1060 (482)
	15	2FPRAM44-376F-40PI	40	87 (2210)	1375 (625)
	23	2FPRAM44-386F-40PI	40	87 (2210)	1375 (625)
	15	3FPRAM55-376F-40PI	40	112 (2845)	1690 (768)
	23	3FPRAM55-386F-40PI	40	112 (2845)	1690 (768)
	15	4FPRAM66-376F-40PI	40	137 (3480)	2005 (911)
	23	4FPRAM66-386F-40PI	40	137 (3480)	2005 (911)



Contact Principles

Model FI and NI Vacuum Interrupter Mechanism Principle

Add to appropriate switch specifications.

Ratings for FI modules available through 25kV, with 12.5kA symmetric interrupting. Ratings for NI modules available through 35kV, with 12.5kA, 20kA and 25kA symmetric interrupting.

The model FI and NI vacuum interrupters consist of three vacuum bottles mechanically linked to a single spring-assisted operating mechanism. Once initiated, the interrupting time of the vacuum bottles is approximately 3 cycles (50 millise). A position indicator (open-green, closed-red) driven by the operating mechanism and is visible through a viewing window for positive contact position. The mechanical linkage assembly provides a "trip-free" operation permitting the vacuum interrupter to interrupt independent of the operating handle if closing into a faulted circuit.

The control monitors the current on each phase and activates a trip solenoid to open the three vacuum bottles if an overcurrent on any phase is sensed. The control is self-powered by current transformers mounted inside the sealed switch tank. No external power source is required. Load current is required for the control to be activated unless the optional remote power feature is specified. The trip selector is used to select the time-current response curve for the tap circuits. The time-current response curves are chosen with the phase selector switches on the face plate of the control. Selection of time-current characteristics may be made under load or no-load conditions with continuous current ranges in twelve selectable levels.

The manual trip and reset of the vacuum interrupter is accomplished through a single handle operating all three phases simultaneously.

Motor actuators can be provided. Optional push-button on the controls also permit manual tripping.

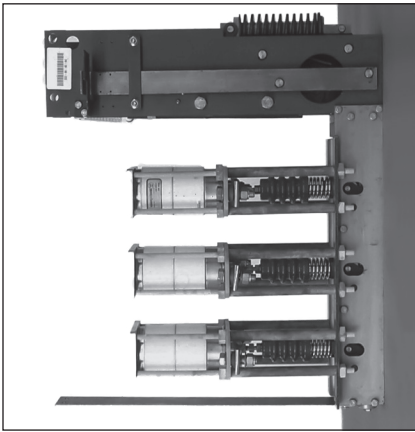

Model FI three phase mechanism.

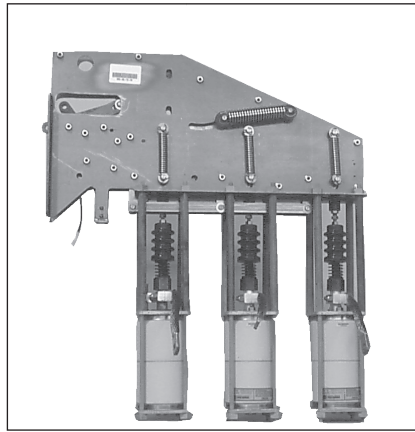

Model NI three phase mechanism.



Three phase interrupter operating handle for manual three phase operation and reset.



Motor actuators (below) can be added for remote operation.

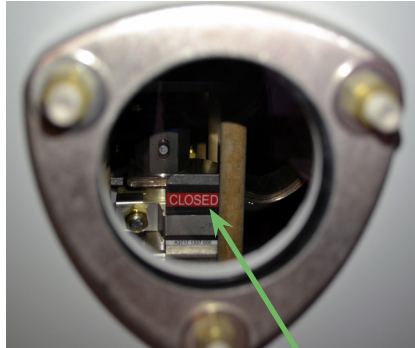

Position indicators provide visible verification of contact position through viewing windows.



Model VI Vacuum Interrupter Mechanism Principle

Add to appropriate switch specifications.

Ratings available through 35kV, with 12kA interrupting with an option for 20kA. Mechanisms are field retrofittable between single phase and three phase operation.

For single phase operation, the model VI vacuum interrupter consists of a single vacuum bottle mechanically linked to a spring-assisted operating mechanism. For three phase operation, the single phase mechanisms are mechanically linked together with an external operating handle assembly. These mechanisms are field retrofittable between single phase and three phase operation. In both cases, once initiated, the interrupting time of the vacuum bottles is approximately 3 cycles (50 millisecond). A position indicator (open-green, closed-red) is mounted to the moving contact and is visible through a viewing window for positive contact position. The mechanical linkage assembly provides a "trip-free" operation permitting the vacuum interrupter to interrupt independent of the operating handle if closing into a faulted circuit.

The control monitors the current on each phase and activates a trip solenoid to open one or all three vacuum interrupters if an overcurrent on any phase is sensed. The control is self-powered by current transformers mounted inside the sealed switch tank. No external power source is required. Load current is required for the control to be activated unless the optional remote power feature is specified. The trip selector is used to select the time-current response curve for the tap circuits. Factory setting for single or three phase tripping is standard. The time-current response curves are chosen with the phase selector switches on the face plate of the control. Selection of time-current characteristics may be made under load or no-load conditions with continuous current ranges in twelve selectable levels.

The manual trip and reset of the vacuum interrupter is accomplished through an operating handle. Motor actuators can be provided for remote control. Optional push-button on the control also permits manual tripping.

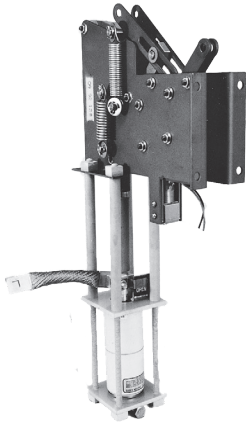

Interrupter operating handles for manual single phase (left) or three phase (right) operation and reset. Motor actuators can be added to three phase for remote operation.

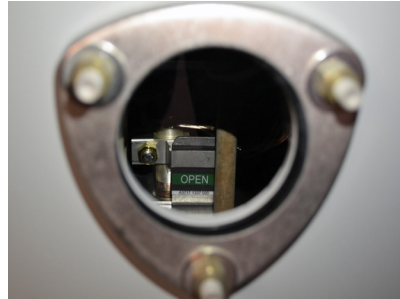

Position indicators provide contact position indication through viewing windows.

Two Position, Rotary Puffer Style

G&W's patented Rotary Puffer (RP) style, two-position switches are ideal for manual load break switching, automatic transfer or automated sectionalizing applications rated through 25kV, 630A continuous. This module allows for the smallest switch footprint. Switches are tested to 500 loadbreak operations at 15kV and 350 operations at 25kV. Switches also tested to 2000 mechanical operations. Current limiting fuses or electronically controlled vacuum interrupters can be added for overcurrent protection. G&W Electric's RP style contact system provides extremely efficient, high speed arc extinction for maximum service life.

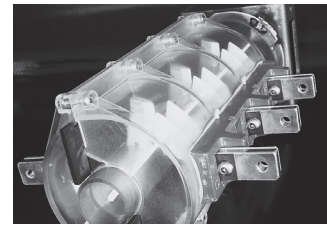

Two position rotary puffer mechanisms.

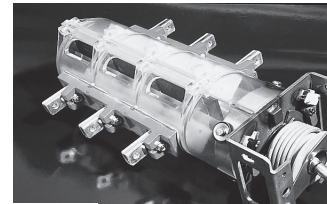

Two Position, Rotary Puffer Contact Principle

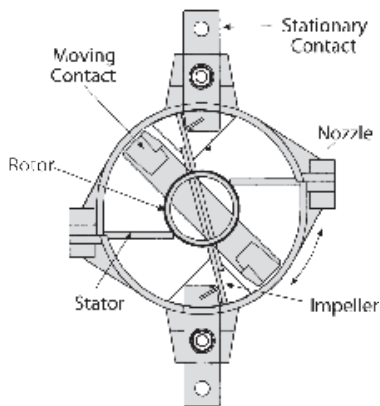

A. Components

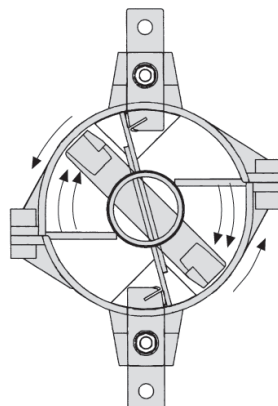

B. Gas flow opening

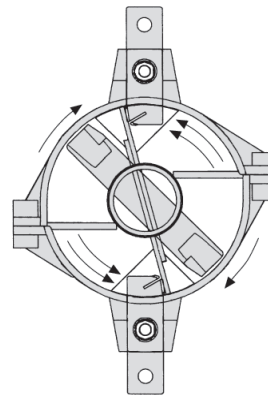

C. Gas flow closing

A. The stationary contacts and the multi-chamber rotor (an assembly of interlocking parts which form a rotational framework including moving contacts) are housed in a clear cylindrical shell. The stationary contacts are supported independent of the cable entrance bushings, eliminating possible misalignment resulting from tank deflections. Tank deflections are caused by normal tank pressure variance due to ambient temperature fluctuations. Each rotating contact simultaneously disengages from two stationary contacts, providing two break points per phase. This provides improved interrupting capability as compared to single break contact systems.

B. As the rotor tube assembly turns to disengage the moving contact from the stationary contacts, dielectric media (gas) is compressed between the impeller and stator. The shell, phase barrier and rotor tube also act to confine the gas for proper compression and flow. The compressed gas is directed through the nozzle into the arc zone. The gas flows (is puffed) across the contacts and around the arc established by the separating contacts, cooling the arc over the length of the nozzle. The cooling action is increased by the higher pressure (due to compression) and the flow of gas which constantly provides a supply of cool gas into the arc zone.

At current zero, the temperature of the arc is reduced to the point of deionization. The gas rapidly recovers dielectric strength withstanding the system recovery voltage and preventing re-ignition of current across the contacts.

C. As the rotor tube assembly turns to engage the moving contact with the stationary contacts, the impeller induces a flow of gas between the contacts to minimize pre-strike.

Two Position, Linear Puffer Style

G&W Electric's patented Linear Puffer (LP) style, two-position switches are ideal for heavy duty manual load break switching, automatic transfer or automated sectionalizing applications rated through 35kV, 900A continuous and 40kA asymmetrical short circuit. Switches are tested to 1200 loadbreak and 2000 mechanical operations. Current limiting fuses or electronically controlled vacuum interrupters can be added for overcurrent protection. G&W Electric's LP style contact system provides extremely efficient, high speed arc extinction for maximum service life.



Three phase visible position of contacts.

Stored Energy Mechanism

Linear puffer switches can be supplied with internal stored energy (cock and trip) mechanisms for both the open and close operators permitting high speed local or remote operation. A separate external trip handle is provided. An optional internal solenoid permits remote operation.

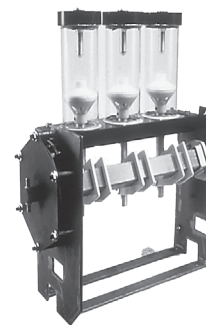

Three phase linear puffer mechanism.

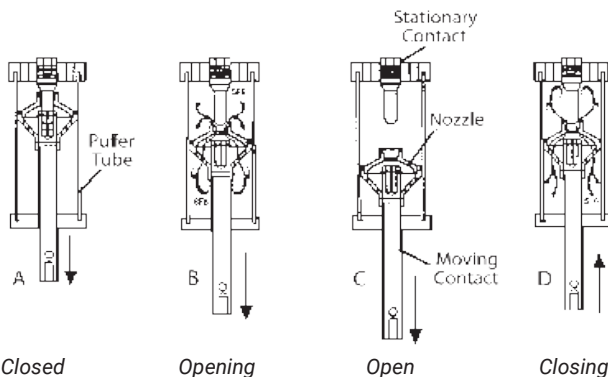

A. The stationary contact and piston assembly (containing the moving contact and nozzle) are housed in clear cylindrical tubes. These are mounted in a modular three-phase assembly which is independent of the switch tank. The stationary contacts are supported independent of the cable entrance bushings, eliminating possible misalignment resulting from tank deflections. Tank deflections are caused by normal tank pressure variance due to ambient temperature fluctuations. This construction eliminates contact alignment difficulties caused by deflections of the switch tank walls. The modular construction also allows testing of the module during assembly and complete flexibility in switch design and configuration. The nozzle which directs the flow of gas has a converging/diverging geometry (see photo) which improves the arc interruption capability over designs using straight throated nozzles. The converging portion of the nozzle has a constantly decreasing flow area up to the nozzle throat minimizing velocity changes in the flow of gas, while improving arc interruption and dielectric recovery.

Two Position, Linear Puffer Style con't

B. As the contacts separate, the gas is compressed by the piston assembly and directed into the arc zone by the nozzle. The compressed gas flows (is puffed) across the contacts and around the arc established by the separating contacts. The cooling action of the gas is increased by the higher pressure (due to compression) and the flow which constantly provides a supply of cool gas into the arc zone.

C. At current zero the temperature of the arc is reduced to the point of deionization, ceasing the flow of current. The gas rapidly recovers dielectric strength withstanding the system recovery voltage across the contacts.

D. As the contacts are closing, the piston assembly compresses the gas between the contacts. This increases the dielectric strength of the gap, minimizing prestrike. The contacts are designed using a tulip bayonet construction (see photo). The sliding action of the contacts on engagement provides a self cleaning action of the main current carrying surfaces. The contact fingers are designed for increasing contact pressure with increasing current for proper operation during momentary or close-into-fault conditions. The contacts have arc resistant copper tungsten tips to minimize erosion of material during load switching and prevent damage to the main current transfer area of the contacts.

Three Position, Rotary Puffer Style

For systems through 35kV, 630A continuous current with 40kA asym. momentary, 32kA asym. close into fault, and 25kA sym. one second current; rotary puffer (RP) style switches are used. G&W Electric's multi-position spring operator permits an integral third switching position to increase the application capability over conventional two position switches. Three position switches combine increased switching flexibility with compact construction.

A. The stationary contacts and the multi-chamber rotor (an assembly of interlocking parts which form a rotational framework including moving contacts) are housed in a clear cylindrical shell. The stationary contacts are supported independent of the cable entrance bushings, eliminating possible misalignment resulting from tank deflections. Tank deflections are caused by normal tank pressure variance due to ambient temperature fluctuations. Each rotatin contact simultaneously disengages from two stationary contacts, providing two break points per phase. This provides improved interrupting capability as compared to single break contact systems.

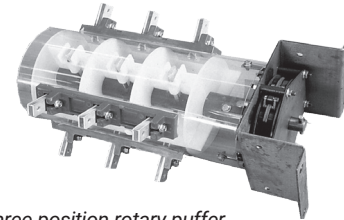

Three position rotary puffer mechanism.

B. As the rotor tube assembly turns to disengage the moving contact from the stationary contacts, dielectric media (gas) is compressed between the impeller and stator. The shell, phase barrier and rotor tube also act to confine the gas for proper compression and flow. The compressed gas is directed through the nozzle into the arc zone. The gas flows (is puffed) across the contacts and around the arc established by the separating contacts, cooling the arc over the length of the nozzle. The cooling action is increased by the higher pressure (due to compression) and the flow of gas which constantly provides a supply of cool gas into the arc zone.

C. At current zero, the temperature of the arc is reduced to the point of deionization. The gas rapidly recovers dielectric strength withstanding the system recovery voltage and preventing re-ignition of current across the contacts.

D. As the rotor tube assembly turns to engage the moving contact with the stationary contacts, the impeller induces a flow of gas between the contacts to minimize pre-strike.

Three Position, Rotary Puffer Contact

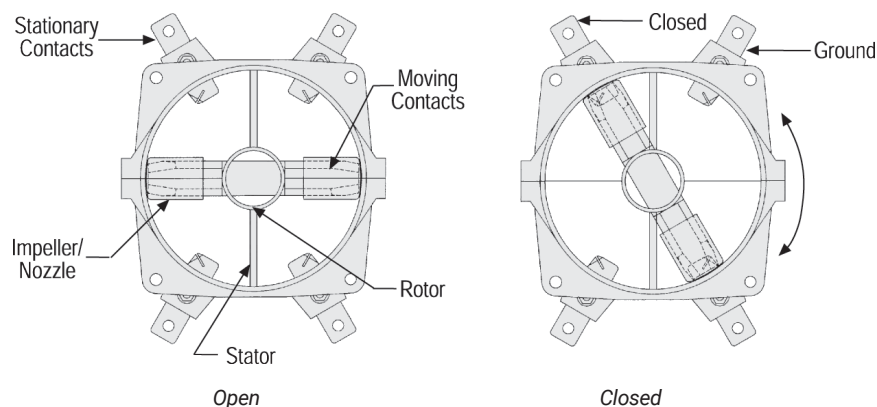

Switch Remote Control Packages

For electrical remote operation, motor actuators can be added. Various control packages are available:

Single way controls.

- Either stationary or portable
- Powered by 120 or 240VAC or up to 125VDC
- AC powered controls are available with or without battery backup.

Multi-way controls

- Switch controls, such as Schweitzer's SEL 451, are available for applications requiring one control to operate numerous switch ways on one switch or numerous switches from one control.



Padmount switch with SEL controls.

LaZer® Power Grid Automation

The G&W Electric LaZer® Automation System is the culmination of decades of experience designing innovative power automation solutions. From simple automatic transfer schemes to the most complex SCADA/master station configurations, our comprehensive solutions are custom engineered to meet your precise application needs.

LaZer Power Grid Automation solutions combine proven power grid hardware and software with decades of system integration experience that can reduce or eliminate outage costs and improve your bottom line.

Lazer is a protection and control package that features one or more protective relays, equipped with distributed capabilities and peer-to-peer communication to make intelligent operating decisions and to monitor field conditions. Lazer focuses on critical load installations to maximize service reliability.

G&W Electric's LaZer Power Grid Automation solutions combine proven power grid hardware and software with decades of system integration experience that can reduce or eliminate outage costs and improve your bottom line. The system specifically addresses fault detection, isolation and restoration (FDIR) requirements. It continuously monitors the circuit. When it senses an electrical overload or short circuit fault within its protection zone, it issues a command to the appropriate switchgear to trip-open within a pre-determined time delay based on the severity of the fault.

Communication with other upstream and downstream Lazer devices function continually to determine what other actions are required to reconfigure the circuits to automatically restore power to customers connected to the unfaulted lines. The entire process from fault detection to system restoration can typically be completed within 60 seconds or less.

Flexible communication and open protocols are critical for integrating to existing Smart Grids and expanding to handle future needs. Lazer solutions offer flexible communication using hardwired connections, fiber optic cable, or a range of wireless technologies on RS232, RS485, and Ethernet ports. Some of the different protocols available are:

- DNP 3.0
- SEL Mirrored Bits® (proprietary)
- IEC61850 with GOOSE messaging

Project Examples

- Distributed automatic transfer including reclosers and SEL-451 controls over fiber optic cable.
- Open Loop FDIR including switches, ABB REC670 relays and ABB RTU560 HMI.
- Closed Loop FDIR including switches, SEL-351s and Survalent software.
- Open Loop Upgrade including switches, SEL-451 and SEL-751A over fiber optic.
- High Speed Single Phase Tripping Closed Loop including reclosers and SEL-651R over fiber optic cable.

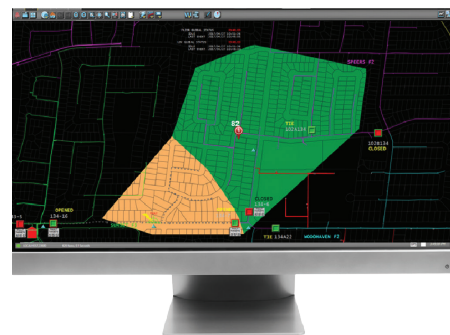

Automatic Transfer

ATC 451

G&W Electric's ATC 451 automatic transfer controls are available for G&W Electric gas switchgear through 38kV. Switches can be dry or submersible padmount or pole mount styles. The two incoming source ways can be located in one switch, or in two separate switches for added redundancy. Manual switches can be retrofitted in the field. Standard transfer times are within 8-10 seconds.



ATC 451 control panel.

Features:

- Uses SEL 451 relay - ATC 451 control utilizes the field proven Schweitzer SEL 451 relay for its protection logic and programming scheme
- Plug and play construction - The ATC 451 is pre-programmed and packaged with all required components to simplify installation and maximize reliable performance. Various styles of NEMA enclosures are available depending on the application.
- Overcurrent protection for two fault interrupting ways - The ATC 451 can eliminate the need for separate vacuum interrupter controls. Depending on user preference and system protection schemes, various styles of separate interrupter controls are available.
- SCADA ready - Each ATC 451 comes standard with several serial ports for communication to SCADA systems. Multiple protocols are available including DNP3.0 (standard), Mirrored Bits (standard), and IEC 61850 (option). Ethernet or fiber optic ports for communications are also available options.
- Lazer[®] ready - The SCADA ready capability simplifies the requirements for communication to other intelligent field devices for automatic power restoration schemes. This simplifies the integration of the ATC into any G&W pre-engineered Lazer automation system where automatic transfer is required.
- Generator source capability - The 451 can be programmed to permit a standby generator to be used instead of a second utility source.
- Bus tie configurations - The ATC 451 can be used with a bus-tie switch permitting automatic transfer where the load is normally balanced between two sources.
- User friendly controls - Large pushbuttons are clearly labeled and provide easy control commands from the front panel.
- Sequence of event recorder - Each ATC 451 includes a Sequence of Events Recorder which will record the last 1000 entries, including setting changes, powerups, and selectable logic elements.
- Flexible voltage sensing options Integral voltage sensing bushings are available which eliminate the need for cumbersome add-on devices. The bushings are 600A rated, fully submersible, and provide one analog output per phase and one digital output per way for voltage monitoring (when using amplification circuitry). Elbow mounted sensors and potential transformers are also available.

Faster Transfer Speed Options

Switches can be provided with internal cock-and-trip (stored energy) mechanisms permitting transfer times within 15-20 cycles. These switches incorporate an external, hookstick operable handle permitting manual open or close without having to disconnect the motor actuator. Contact G&W if faster transfer times are required.

G&W Electric Vacuum Interrupter Controls

The control monitors the current, sends a trip signal which opens the vacuum interrupters and interrupts the fault current. G&W Electric controls are self-powered from the current transformers located inside the solid dielectric module. Controls can be equipped to accept a trip input from a relay or communication device. G&W also offers other controls, such as SEL relays, depending on the application. The standard control enclosure for padmount applications is fiberglass NEMA 4X (IP56) rated. For padmount and subsurface applications, G&W Electric recommends the Type 7 control. The Type 7 control is mounted within the switch's mechanism housing and has an IP68 rating for long term submersion.

Control Options

Type 1

Controls operate three, single phase vacuum interrupting mechanisms. The Type 1 control can be field set for either single phase or three phase trip mode. It is used on switches with either single phase reset or three phase reset handles. When in the three phase mode, all three phases trip if the selected trip level of any individual phase is reached. Trip level selections can be made under load or no-load conditions with 12 selectable minimum trip settings. Two ranges of minimum trip settings are available, 15 to 300 Amps and 30 to 600 Amps. Each unit is pre-programmed with 30 user selectable Time Current Characteristic (TCC) curves. The curve selection can be set or changed while the switch is energized. An 8 pole dip switch allows the user to choose the TCC that best matches their individual coordination requirements. A label provides a key for the dip switch settings. The control can be factory preset to meet the user's requirements. As protection or coordination requirements change, settings can easily be changed while the switch is energized. Pressing the manual trip button when the control is powered, electronically trips all three phases of the vacuum interrupter. Each control also includes "Last Cause of Trip" LEDs. These LEDs indicate which phase experienced an overcurrent condition, or that the control was given an external or manual trip command.



Type 1 control

Type 2

Controls provide a user friendly interface for quick and easy programming. Trip level selections can be made under load or no-load conditions with current ranges in 12 selectable levels. Two ranges of minimum trip settings are available, 15 to 300 amps and 30 to 600 amps. Each unit is pre-programmed with 30 Time Current Characteristic (TCC) curves. The curve selection can be set or changed at any time. An 8 pole dip switch allows the user to choose the TCC curve which best matches their specific coordination requirements. The control can be factory preset to meet the user's requirements. As protection or coordination requirements change, settings can easily be changed in the field. Pressing the manual trip button when the control is powered up trips all three phases of the vacuum interrupter. Each control also includes "Last Cause of Trip" LEDs. These LEDs indicate what caused the control to issue a trip command -an over current condition, Ground Fault, Instantaneous, or an external or manual trip command. Type 2 controls offer the following features:



Type 2 control

- Three phase protection
- Minimum trip setting for all three phases with one selector switch
- Adjustable phase time delay
- Ground fault (phase imbalance) for protection of large three phase motors or transformers. The ground trip setting is represented as a percent of the minimum trip setting.
- Instantaneous trip and inrush restraint features

Accessories and Options con't

Type 3 and 4 controls provide advanced protection functions. There are two versions of these controls, each with different protection elements. The EZset version includes:

- Phase Minimum Trip
- Phase Time Delay
- Phase Instantaneous
- Phase Minimum Responses
- Phase Inrush (Cold Load Pickup) Restraint
- Ground Fault ((phase imbalance) Minimum Trip with Separate Curve
- 30 Phase/Ground Fault Curve selectors

The Plus version includes all of the above, and in addition includes

- Ground Fault Time Delay
- Ground Fault Instantaneous
- Ground Fault Minimum Responses
- Ground Fault Inrush (Cold Lead Pickup) Restraints
- 60 Phase/Ground Fault curves including 5 User Creatable Curves
- Maintenance Setting Group

The Type 3 and 4 controls record the 16 most recent Cause of Trip Events.

The Type 3 EZset includes a display and keypad for entering programming parameters and viewing the Cause of Trip Events. The Type 3 Plus, and Type 4 EZset and Plus utilize a laptop programming kit to enter the settings. The laptop programming kit can also be used to download and store the settings and Cause of Trip Events.



Type 3 control



Type 4 control in IP68 rated enclosure

3-1/C, 600A or 200A Voltage Sensing Bushings

G&W Electric's Voltage Sensing Bushing (VSB) system is a temperature compensated, built-in, voltage measuring system that eliminates the need for PTs when analog phase to ground voltage monitoring is required. Compared to potential transformers, the VS bushing system offers these benefits:

- Significant cost savings
- Cleaner, less cumbersome installation
- Less space required
- Fewer add-on components which could potentially fail
- Installed and tested prior to shipment
- Can be field calibrated

The VS bushing system utilizes a capacitively coupled screen which is embedded within the epoxy bushing. The low energy output of the screen can be directly read by some relays. Alternatively, the output is amplified by integral circuitry, resulting in a 0-120 VAC analog output suitable for direct connection to any relay, IED or RTU. The circuitry incorporates built-in calibration and temperature compensation which improve accuracy.

600A Voltage Sensing Bushings

Bushings are designed to IEEE 386 standards with standard interface accepting conventional elbow style connectors and include an aluminum conductor with 5/8"-11 aluminum threaded stud and aluminum single hole pad (elbows must be ordered separately). Bushings are bolt-on style. Copper studs are available. For bottom entry switches, recommended switch frame height is 42" for all voltages.



600A voltage sensing bushings

200A Voltage Sensing Bushings

Bushings are designed to IEEE 386 standards with standard interface accepting deadbreak or loadbreak inserts and conventional elbow connectors (inserts and elbows must be ordered separately). A copper conductor is standard. For bottom entry switches, recommended switch frame height is 42" for all voltages.



200A voltage sensing bushings

3-1/C, 600A Quik-Change Apparatus Bushings

Cable entrance bushings can be damaged at any time due to improper handling, accidental shifting during shipment, elbow failure or even normal wear and tear. In the case of gas insulated switches where the tank is totally welded, conventional bushing replacement means sending the switch back to the factory for repair. G&W Electric's exclusive Quik-Change Disconnectable Bushing permits quick, easy field replacement without having to open the switch tank.

Bushings are designed to IEEE 386 standards with standard interface accepting conventional elbow style connectors and include an aluminum conductor with 5/8"-11 aluminum threaded stud and aluminum single hole pad (elbows must be ordered separately). Copper studs are available. For bottom entry switches, recommended switch frame height is 42" for all voltages.

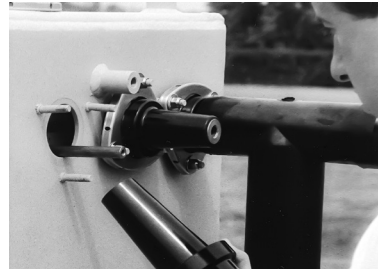

3-1/C, 600A / 900A Apparatus Bushings

Bushings are designed to IEEE 386 standards with standard interface accepting conventional elbow style connectors and include an aluminum conductor with 5/8"-11 aluminum threaded stud and aluminum single hole pad for a 600A rating (elbows must be ordered separately). A copper conductor is available which extends the continuous current rating to 900A. For bottom entry switches, recommended switch frame height is 42" for all voltages. Welded flange bushings are available.



3-1/C, 600A Apparatus Bushings - Welded Flange style

Bushings are designed to IEEE 386 standards with standard interface accepting conventional elbow style connectors. Bushings include a stainless steel flange and an aluminum conductor with 5/8"-11 aluminum threaded stud. Elbows must be ordered separately. 200A deepwell welded flange bushings are also available.

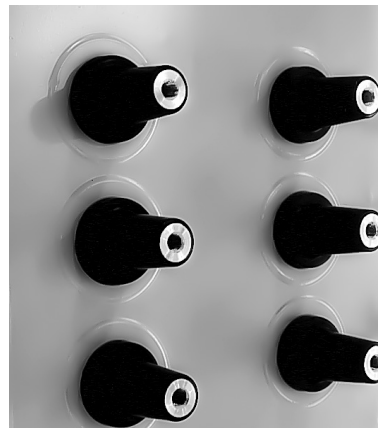

3-1/C, 200A Deepwell Bushings

Bushings are designed to IEEE 386 standards with standard interface accepting deadbreak or loadbreak inserts and conventional elbow connectors (inserts and elbows must be ordered separately). A copper conductor is standard. For bottom entry switches, recommended switch frame height is 42" for all voltages. Welded flange bushings are available.



Viewing Windows (Standard) - Provide a means to visibly verify switch contact position. Single phase or three phase contact viewing is available. Ground Lugs (Optional) - Are bronze, eyebolt style for 4/0 maximum conductor cable.

For standard components, refer to typical specifications at www.gwelec.com under Resources & Support.

Gas Pressure Gauge and Fill Valve (Standard)

The pressure gauge is a “GO-NO-GO” style which is color coded to simplify verification of proper operating conditions. A Schraeder type fill valve permits refilling in the field. The gauge and fill valve are made of brass for corrosion resistance. Both components are protected by a steel guard.



Low Pressure Warning Devices

Are factory set at 5 psig and permit remote indication of internal tank pressure. It can also be used for low pressure control lockout. One Form C contact is provided for wiring by the customer.

Recommended for installations where ambient temperature does not fall below 0°F (-15°C).



Temperature Compensated Gas Density Gauge (Optional)

Measures internal tank gas density for maximum precision of switch operating conditions. The gauge is colored coded to simplify reading by operating personnel.



Gas Density Switches

Permit remote indication of internal tank gas density to assure proper pressure/temperature operating conditions. One Form C contact is provided for wiring by the customer.

Recommended for installations where ambient temperatures fall below 0°F (-15°C).



VI control window cover (Optional)

The standard control enclosure for padmount applications is fiberglass NEMA 4X (IP56) rated. The control is also available with an option for a fiberglass NEMA 4X (IP56) enclosure with a viewing window.



Key Interlocks (Optional)

May be used as an added safety measure to prevent operation by unauthorized personnel or to assure safe coordination of energized equipment. Switches can be provided with provisions only (two maximum per operating mechanism) or with key interlocks factory installed. Specify locking scheme when ordering, i.e. lock in open, lock in closed or lock in both open and closed position. For key interlocks to be coordinated with other equipment, manufacturer’s information must be provided.

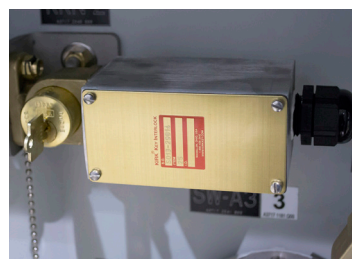

Accessories and Options

Options

Select from the following options and add to the appropriate switch specification:

- Stainless steel tank, type 304
- Stainless steel enclosure, type 304 or 316
- Temperature compensating pressure gauge
- Low pressure warning device
- Gas density switch
- 4/0 brass ground lug
- Key interlock provisions
- Key interlocks to lock in open position
- Current transformers for load break ways
- Potential transformers for voltage monitoring and/or control power
- Automatic transfer control type ATC451
- Motor actuators for remote switch operation
- Auxiliary switches for remote switch position indication
- Stationary switch controls for remote switch operation and SCADA integration
- Portable switch controls for remote switch operation
- Remote terminal units and communication packages for SCADA integration
- Operation counters
- Voltage sensors with 120 VAC output or a contact to indicate presence of voltage
- 200A deepwell bushings
- 600A apparatus bushings
- 200A voltage sensing bushings
- 600A voltage sensing bushings
- 600A Quik-Change apparatus bushings
- 600A Universal bushings (through 25kV)
- Type 2 vacuum interrupter control including ground fault trip and time delay selector switches (three phase only)
- Type 3 vacuum interrupter control including ground fault trip, inrush restraint, programmable vacuum fluorescent display (VFD)
- Type 4 vacuum interrupter control (same as Type 3 with laptop programming only)
- Clear window cover for Type 1, Type 2, or Type 3 interrupter controls
- Submersible NEMA 6P enclosure or IP68 potted Type 4 for vacuum interrupter control
- SEL relays including 451 and 751A
- ABB relays including REF615, REF620, and REC670
- GE relays including 350, F35, and F60
- External power / trip for vacuum interrupter control
- Refill kit consisting of regulator, hose and gas bottle

Specifications

General Ratings

Use on: Grounded wye systems

- Operating temperature: -40°C to +65°C
- Storage temperature: -50°C to +65°C

Input Ratings

Input voltage range (phase to ground) options:

- Low Energy: 1.2 - 4.61 or 4.62 - 21.9kV
- Amplified: 1.7 - 6.2 or 6.2 - 21.9
- Frequency range: 48Hz - 61.2Hz

Output Ratings

Low Energy output voltage:

- 8 VAC

Low Energy Relay Input Impedance:

- 1M Ω

Nominal amplified output voltage:

- 120 VAC with digital output contact (1 per 3 phase set)

Digital pick-up voltage:

- 90% of Vnom (on all phases)

Digital drop-off voltage:

- 75% of Vnom (on any phase)

Maximum burden (per output):

- 0.06VA

Low Energy accuracy:

- +/- 4% from -40°C to 65°C
- (+/- 2% from -20°C to 65°C)

Amplified accuracy:

- +/- 5% from -40°C to 65°C



DISTRIBUIDOR AUTORIZADO:

Teléfono: +52 (81)8365-0229
ventas@altatecnologia.com.mx
altatecnologia.com.mx

Contact us today

+1.708.388.5010 or info@gwelec.com



Since 1905, G&W Electric has been a leading provider of innovative power grid solutions, including the latest in load and fault interrupting switches, reclosers, system protection equipment, power grid automation and transmission and distribution cable terminations, joints and other cable accessories. G&W is headquartered in Bolingbrook, Illinois, U.S.A., with manufacturing facilities and sales support in more than 100 countries, including Canada, Italy, China, Mexico, Brazil, India, UAE and Singapore. We help our customers meet their challenges and gain a competitive edge through a suite of advanced products and technical services.